

KYORITSU

Test and Measuring Instruments
General Catalogue 2016 - 2017



Japan
QUALITY

KYORITSU

NEW PRODUCTS



2117R

- Large easy-to-read display with 0.01A resolution.
- NCV (Non Contact Voltage)
- Safety Standard IEC61010-1 CAT IV 300V / CATIII 600V

TRUE RMS

P20



1021R

- Large display with 6000 counts and backlight
- Enhanced current measuring function using an external clamp sensor
- Safety Standard IEC61010-1 CAT IV 300V / CATIII 600V

TRUE RMS

P10



4105DL

- Less affected by current spike resistance and earth voltage
- IP67 - Can measure in bad weather conditions

IP67

P42



6024PV

































- Correct measuring for insulation resistance even if the panel is under power
- IP54 - Can measure in bad weather conditions

IP54

P56

CONTENTS

SYMBOLS

	TRUE RMS
	CAT IV 600V
	DC/AC V
	DC/AC A
	DC Voltage
	AC Voltage
	DC Current (A)
	AC Current (A)
	DC+AC measurement
	MAX MIN AVG
	MAX MIN
	Resistance
	Continuity buzzer
	Diode
	Capacitance
	Temperature
	Frequency
	Decibel
	Duty cycle ratio
	Non Contact Voltage
	Back light
	Water proof
	Peak hold
	Data hold
	Auto power off
	Auto power save
	Output
	Filter
	Relative
	External Power Supply
	USB
	Low power Ω
	Bluetooth

MULTIMETERS

1009, 1011/1012, 1018/1018H, 1019R, 1020R/1021R, 1030, 1051/1052, 1061/1062, 1109S, 1110, 2000/2001, 2012R

P.8 - P.15

CLAMP METERS

2002PA/2002R, 2003A, 2007R, 2009R, 2010, 2031, 2033, 2046R, 2055/2056R, 2117R, 2127R, 2200/2200R, 2204R, 2210R, 2300R, 2413F/2413R, 2431, 2432, 2433/2433R, 2434, 2500/2510, 2608A, 8112/8112BNC, 8115, 8161

P.16 - P.27

INSULATION TESTERS

3005A, 3007A, 3021/3022/3023, 3025A/3125A, 3121B/3122B, 3123A, 3124, 3127, 3128, 3131A, 3132A, 3161A, 3165/3166, 3431

P.28 - P.39

EARTH TESTERS

4102A, 4105A, 4105DL, 4106, 4200/4202, 4300

P.40 - P.45

LOOP/PSC/RCD TESTERS

4118A, 4140, 5406A, 5410

P.46 - P.49

PORTABLE APPLIANCE TESTER

6201A

P.50

MULTI FUNCTION TESTERS

6010B, 6011A, 6016, 6018, 6024PV

P.51 - P.57

POWER METERS

6305, 6315

P.58 - P.63

LOGGERS

5010/5020

P.64 - P.65

SENSORS

8121, 8122, 8123, 8124, 8125, 8126, 8127, 8128, 8129, 8130, 8141, 8142, 8143, 8146, 8147, 8148, 8309

P.66 - P.68

OTHERS

5201, 5202, 5510, 5711, 8030, 8031/8031F, 8035

P.69 - P.71

KEWTECH

KT170/171, KT200, KT203

P.72 - P.73

ACCESSORIES

Test Leads

P.74 - P.79

GLOSSARY/PRODUCT INDEX/QUALITY CONTROL CONCEPT

P.80 - P.85



Please read the "Safety Warnings" in the instruction manual supplied with the instrument thoroughly and completely for safety use. Failure to follow the safety rules can cause fire, trouble, electrical shock, etc. Therefore, make sure to operate the instrument on a correct power supply and voltage rating marked on each instrument.

MULTIMETERS

CLAMP METERS

INSULATION TESTERS

EARTH TESTERS

LOOP/PSC/RCD TESTERS

PORTABLE APPLIANCE TESTER

MULTI-FUNCTION TESTERS

POWER METERS

LOGGERS

SENSORS

OTHERS

KEWTECH

ACCESSORIES

GLOSSARY
PRODUCT INDEX
QUALITY CONTROL CONCEPT

KYORITSU LINE UP

ANALOGUE MULTIMETERS

DIGITAL MULTIMETERS

<p>KEW 1109S</p> <p>P11</p>  <p>CE</p>	<p>MODEL 1110</p> <p>P11</p>  <p>CE</p>	<p>MODEL 1009</p> <p>P11</p>  <p>CE</p>	<p>KEW 1011/1012</p> <p>P11</p>  <p>CE 1012 TRUE RMS</p>	<p>KEW 1018/1018H</p> <p>P12</p>  <p>CE</p>	<p>KEW 1019R</p> <p>P12</p>  <p>CE TRUE RMS NEW</p>
---	---	---	--	--	--

ANALOGUE CLAMP METER

DIGITAL CLAMP METERS

<p>MODEL 2608A</p> <p>P19</p>  <p>CE Φ33 MAX AC 300A</p>	<p>MODEL 2002PA MODEL 2002R</p> <p>P19</p>  <p>CE 2002R TRUE RMS Φ55 MAX AC 2000A</p>	<p>KEW 2007R</p> <p>P19</p>  <p>CE TRUE RMS Φ33 MAX AC 1000A NEW</p>	<p>MODEL 2031</p> <p>P20</p>  <p>CE Φ24 MAX AC 200A</p>	<p>KEW 2117R</p> <p>P20</p>  <p>CE TRUE RMS Φ33 MAX AC 1000A NEW</p>	<p>KEW 2127R</p> <p>P20</p>  <p>CE TRUE RMS Φ33 MAX AC 1000A NEW</p>	<p>KEW 2200/2200R</p> <p>P21</p>  <p>CE 2200R TRUE RMS Φ33 MAX AC 600A NEW</p>
--	---	---	---	---	---	---

DIGITAL CLAMP METERS

LEAKAGE CLAMP METERS

<p>KEW 2046R</p> <p>P23</p>  <p>CE TRUE RMS Φ33 MAX AC DC 600A</p>	<p>KEW 2055/2056R</p> <p>P23</p>  <p>CE 2056R TRUE RMS Φ40 MAX AC DC 1000A</p>	<p>KEW 2500/2510</p> <p>P24</p>  <p>CE Φ6 NEW</p>	<p>MODEL 2300R</p> <p>P26</p>  <p>CE TRUE RMS Φ10 MAX AC DC 100A</p>	<p>KEW 2413F/2413R</p> <p>P26</p>  <p>CE 2413R TRUE RMS Φ68 MAX AC 1000A</p>	<p>MODEL 2431</p> <p>P25</p>  <p>CE Φ24 MAX AC 200A</p>
---	---	---	---	---	--

ANALOGUE INSULATION/CONTINUITY TESTERS

ANALOGUE INSULATION TESTERS

HIGH VOLTAGE INSULATION TESTERS

<p>MODEL 3131A</p> <p>P32</p>  <p>CE 3131A(250V/500V/1000V)</p>	<p>MODEL 3132A</p> <p>P32</p>  <p>CE 3132A(250V/500V/1000V)</p>	<p>MODEL 3161A</p> <p>P33</p>  <p>CE 3161A(15V/500V)</p>	<p>MODEL 3165/3166</p> <p>P33</p>  <p>3165(500V) 3166(1000V)</p>	<p>KEW 3431</p> <p>P33</p>  <p>CE 3431(250V/500V/1000V) NEW</p>	<p>KEW 3121B/3122B</p> <p>P34</p>  <p>CE 3121B(2500V) 3122B(5000V) NEW</p>
--	---	--	--	--	---

EARTH TESTERS

LOOP/PSC TESTERS

<p>MODEL 4102A</p> <p>P43</p>  <p>CE</p>	<p>KEW 4105A</p> <p>P43</p>  <p>CE</p>	<p>KEW 4105DL</p> <p>P42</p>  <p>CE NEW</p>	<p>KEW 4106</p> <p>P44</p>  <p>CE</p>	<p>KEW 4300</p> <p>P44</p>  <p>CE TRUE RMS</p>	<p>MODEL 4118A</p> <p>P46</p>  <p>CE</p>	<p>KEW 4140</p> <p>P47</p>  <p>CE</p>
---	--	--	---	---	--	---

MULTI FUNCTION TESTERS

POWER METERS

LOGGERS

OTHERS

<p>KEW 6024PV</p> <p>P56</p>  <p>CE TRUE RMS NEW</p>	<p>KEW 6305</p> <p>P60</p>  <p>CE TRUE RMS NEW</p>	<p>KEW 6315</p> <p>P62</p>  <p>CE TRUE RMS NEW</p>	<p>KEW 5010/5020</p> <p>P64</p>  <p>CE TRUE RMS</p>	<p>MODEL 5201</p> <p>P69</p>  <p>CE</p>	<p>MODEL 5202</p> <p>P69</p>  <p>CE</p>	<p>MODEL 5510</p> <p>P70</p>  <p>CE</p>
--	---	---	---	--	---	---

DIGITAL MULTIMETERS

KEW 1020R/1021R

P10



CE
TRUE RMS

NEW

KEW 1030

P12



CE

KEW 1051/1052

P14



CE
TRUE RMS

KEW 1061/1062

P15



CE
TRUE RMS

MODEL 2000
MODEL 2001

P13



CE

Φ6
Φ10

MAX AC/DC 20A
MAX AC/DC 10A

KEWMATE 2012R

P13



CE
TRUE RMS
Φ12
MAX AC/DC 20A

DIGITAL CLAMP METERS

KEW 2204R

P21



CE
TRUE RMS
Φ70
MAX AC 400A

NEW

KEW 2210R

P21



CE
TRUE RMS
Φ150
MAX AC 3000A

NEW

KEW 2003A

P22



CE
Φ55
MAX AC/DC 2000A

KEW 2009R

P22



CE
TRUE RMS
Φ55
MAX AC/DC 2000A

MODEL 2010

P22



Φ7.5
MAX AC/DC 20A

MODEL 2033

P23



CE
Φ24
MAX AC/DC 300A

LEAKAGE CLAMP METERS

MODEL 2432

P25



CE
Φ40
MAX AC 400A

MODEL 2433/2433R

P25



CE
2433R
TRUE RMS
Φ40
MAX AC 400A

MODEL 2434

P26



CE
Φ28
MAX AC 100A

DIGITAL INSULATION/CONTINUITY TESTERS

MODEL 3005A

P30



CE 3005A(250V/500V/1000V)

MODEL 3007A

P30



CE 3007A(250V/500V/1000V)

KEW 3021-3023

P31



CE
3021(125V/250V/500V/1000V)
3022(50V/100V/250V/500V)
3023(100V/250V/500V/1000V)

HIGH VOLTAGE INSULATION TESTERS

KEW 3123A

P38



3123A(5000/10000V)

MODEL 3124

P39



3124(1k-10kV Variable)

KEW 3025A/3125A

P35



CE 3125A(250/500/1000/2500/5000A)
3025A(250/500/1000/2500A)

NEW

KEW 3127

P36



CE 3127(250/500/1000/2500/5000V)

KEW 3128

P37



CE 3128(500/1000/2500/5000/10000/12000V)

EARTH CLAMP TESTERS

MODEL 4200

P45



CE
TRUE RMS

KEW 4202

RCD TESTERS

MODEL 5406A

P48



CE

KEW 5410

P49



CE

PORTABLE APPLIANCE TESTER

KEW 6201A

P50



CE

KEW 6010B

P52



CE

MULTI FUNCTION TESTERS

MODEL 6011A

P53



CE

KEW 6016

P54



CE

MODEL 6018

P51



CE

OTHERS

KEW 5711

P70



CE

NEW

KEW 8035

P71



CE

MODEL 8030

P71



CE

MODEL 8031

P71



CE

KEW 8031F

P71



CE

KT 170/171

P73



CE

KT 200/203

P72



CE
Φ30
MAX AC 400A

INDUSTRIAL

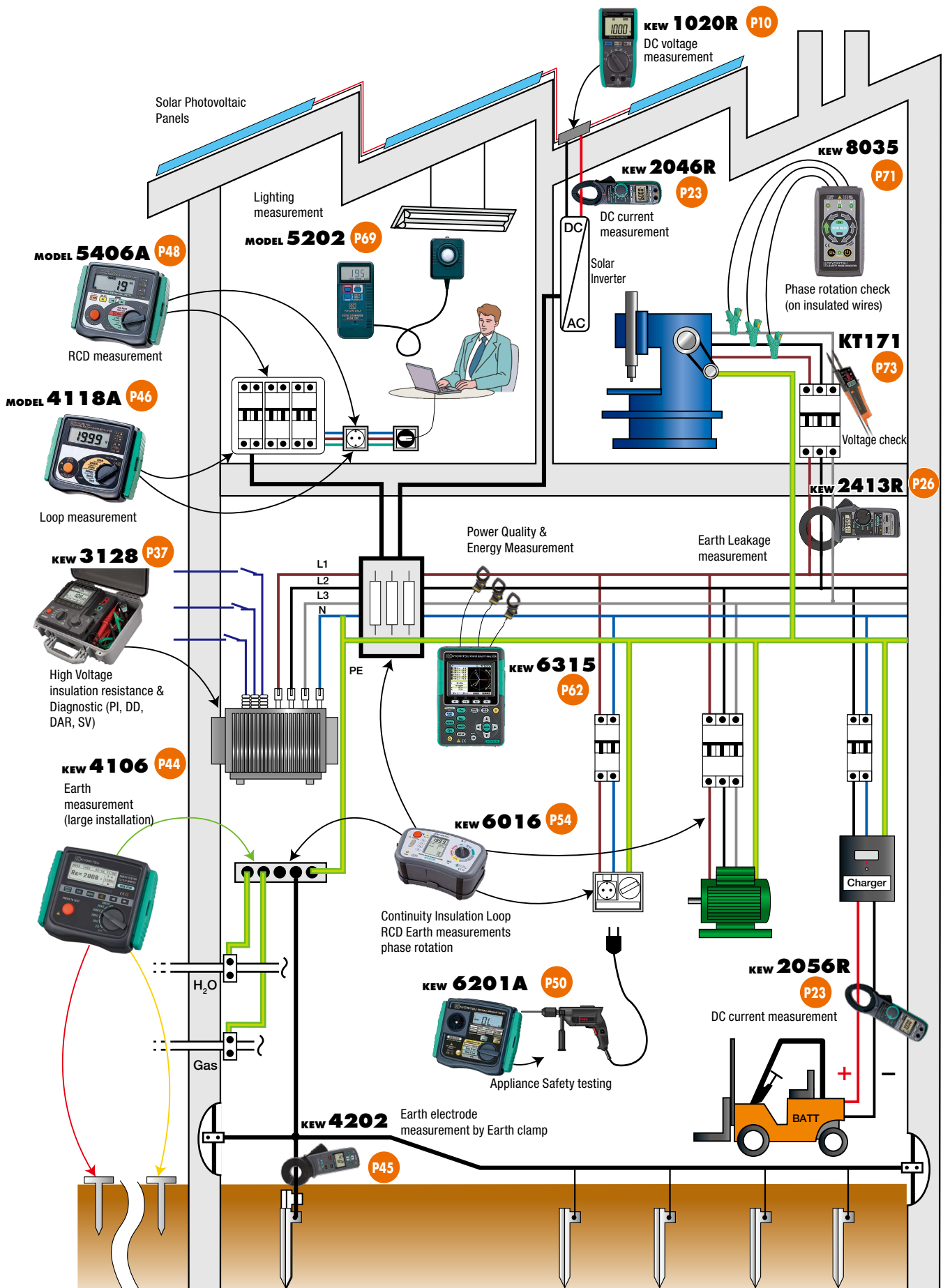

MULTIMETERS

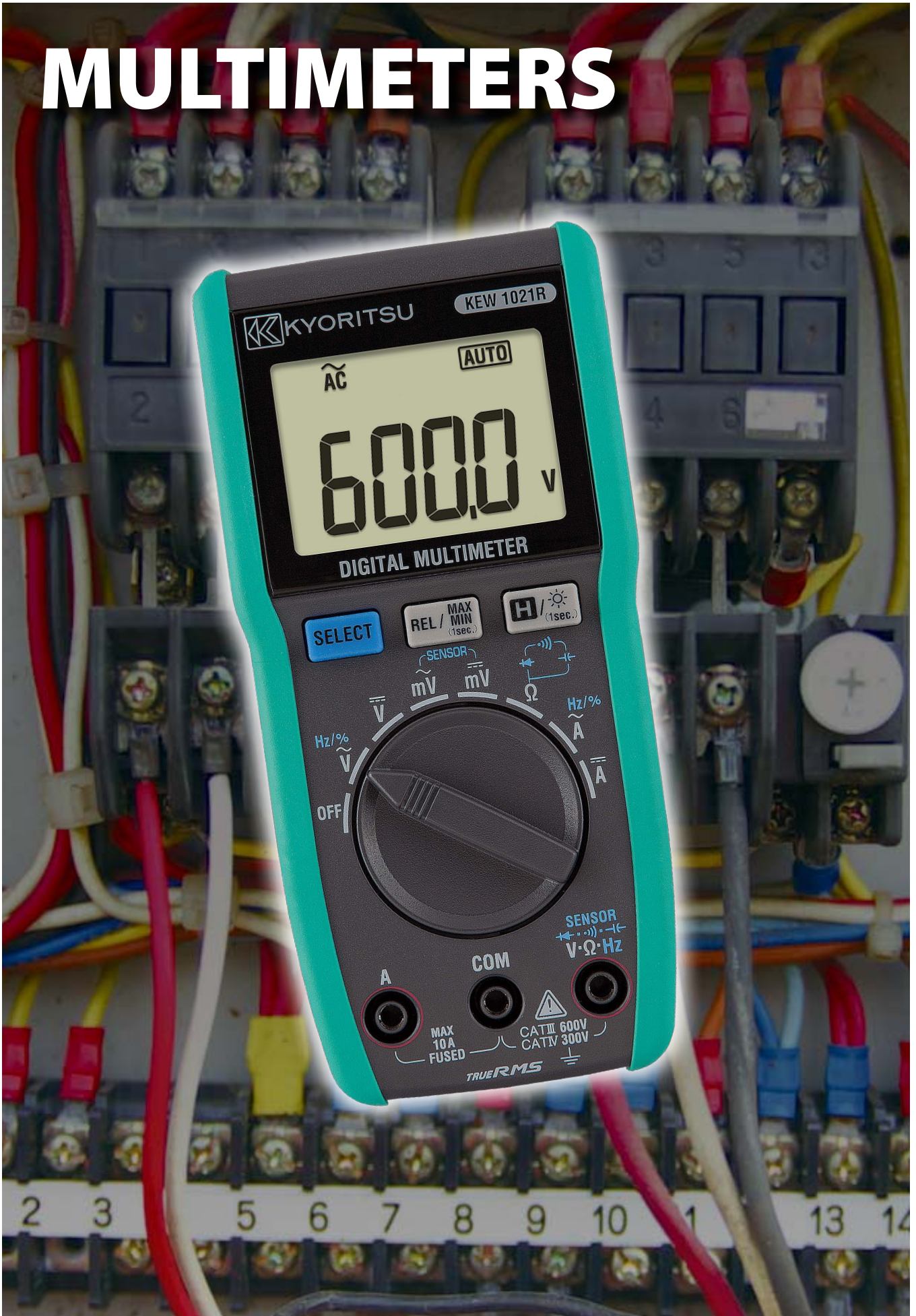

MULTIMETERS

Selection Guide of Multimeters

		Analogue Multimeters		Digital Multimeters										
		1109S	1110	1018 1018H	1019R	1020R	1021R	1030	1009	1011 1012	1051 1052	1061 1062	2000 2001	2012R
Appearance														
Detection method		-	-	-	✓	✓	✓	-	-	✓ (1012)	✓	✓	-	✓
Maximum count display		-	-	4000	6000	6000	6000	4000	4000	6000	6000	50000	3400	6000
DC Basic accuracy		±3% of FS	±3% of FS	0.8%	0.8%	0.5%	0.5%	0.8%	0.6%	0.5%	0.09%	0.02%	1.5%	1.0%
Frequency response		30 - 20kHz	50 - 5kHz	50 - 400Hz	45 - 500Hz	40 - 500Hz	40 - 500Hz	50 - 400Hz	50 - 400Hz	40 - 1kHz	40 - 1kHz	10 - 20kHz(1061) 10 - 100kHz(1062)	50 - 400Hz	45 - 400Hz
Measurement														
DC V	Max	1000V	600V	600V	600V	1000V	600V	600V	600V	600V	1000V	1000V	600V	600V
	Resolution	0.002V	0.005V	0.1mV	0.1mV	0.1mV	0.1mV	0.1mV	0.1mV	0.1mV	0.1mV	0.001mV	0.1mV	0.1mV
AC V	Max	1000V	600V	600V	600V	1000V	600V	600V	600V	600V	1000V	1000V	600V	600V
	Resolution	0.2V	0.2V	0.001V	0.001V	0.1mV	0.1mV	0.001V	0.1mV	0.001V	0.1mV	0.01mV(1061) 0.001mV(1062)	0.001V	0.001V
DCA	DC A	250mA	300mA	-	-	-	10A	-	10A	10A	10A	10A	60A(2000) 100A(2001)	120A
ACA	AC A	-	-	-	-	-	10A	-	10A	10A	10A	10A	60A(2000) 100A(2001)	120A
DC+AC	DC+AC	-	-	-	-	-	-	-	-	-	-	✓	-	-
Resistance	Ω	20MΩ	300KΩ	40MΩ	40MΩ	40MΩ	40MΩ	40MΩ	40MΩ	60MΩ	60MΩ	50MΩ	34MΩ	60MΩ
Continuity buzzer		-	✓	✓	✓	✓	✓	✓	✓	✓	✓	✓	✓	✓
Battery test		-	✓	-	-	-	-	-	-	-	-	-	-	-
Diode test		-	-	✓	-	✓	✓	✓	✓	✓	✓	✓	-	✓
Capacitance		-	-	200μF	600μF	1000μF	1000μF	100μF	100μF	4000μF	1000μF	50mF	-	40μF
Frequency	Hz	-	-	10kHz	-	ACV 99.99kHz	ACA 9.999kHz ACV 99.99kHz	200kHz	10MHz	10MHz	99.99kHz	99.99kHz	ACA 10kHz ACV 300kHz	ACA 400Hz ACV 300kHz
Duty cycle ratio	DUTY	-	-	✓	-	✓	✓	✓	✓	✓	-	✓	-	-
Temperature	°C	-	✓	-	-	-	-	-	-	✓ (1011)	✓	✓	-	-
Decibel	dB	✓	-	-	-	-	-	-	-	-	-	✓	-	-
Low power-Ω	LP-Ω	-	-	-	-	-	-	-	-	-	-	✓ (1062)	-	-
Function														
Dual display		-	-	-	-	-	-	-	-	-	✓	✓	-	-
Bar graph		-	-	-	-	-	-	-	-	✓	✓	✓	✓	✓
Back light		-	-	-	-	✓	✓	✓	-	✓	✓	✓	-	-
Data hold	DATA HOLD	-	-	✓	-	✓	✓	✓	✓	✓	✓	✓	✓	✓
Auto hold		-	-	-	-	-	-	-	-	-	✓	✓	-	-
Peak hold	PEAK HOLD	-	-	-	-	-	-	-	-	-	-	✓ (1062)	-	-
Max/Min/Ave	Max/Min/Ave	-	-	-	-	✓ (No Ave)	✓ (No Ave)	-	-	✓ (No Ave)	✓ (1052)	✓	-	-
REL	REL	-	-	✓	✓	✓	✓	✓	✓	✓	✓	✓	-	-
Manual memory		-	-	-	-	-	-	-	-	-	✓ (1052)	✓	-	-
Logging memory		-	-	-	-	-	-	-	-	-	✓ (1052)	✓	-	-
Communication	USB	-	-	-	-	-	-	-	-	-	✓ (1052)	✓	-	-
Other														
Operating temperature		0 - 40°C	0 - 40°C	0 - 40°C	0 - 40°C	0 - 40°C	0 - 40°C	0 - 40°C	0 - 40°C	0 - 40°C	-10 - 55°C	-20 - 55°C	0 - 40°C	0 - 40°C
Measurement categories		-	CAT III 300V CAT II 600V	CAT III 300V	CAT III 300V CAT II 600V	CAT IV 300V CAT III 600V CAT II 1000V	CAT IV 300V CAT III 600V	CAT III 600V	CAT III 300V	CAT III 300V CAT II 600V	CAT IV 600V CAT III 1000V	CAT IV 600V CAT III 1000V	CAT III 300V CAT II 600V	CAT III 300V CAT II 600V
Power source		R6x2, 6F22x1	R6 x 2	LR-44 x 2	CR2032 x 1	R03 x 2	R03 x 2	LR-44 x 2	R6 x 2	R6 x 2	R6 x 4	R6 x 4	R03 x 2	R03 x 2
Dimensions (L)x(W)x(D)mm		150x100x47	140x94x39	107x54x10	126x85x18	155x75x40*	155x75x40*	190x39x31	161x82x50	161x82x50	192x90x49	192x90x49	128x84x24(2000) 128x92x27(2001)	128x92x27
Weight(Approx.)		330g	280g	70g	135g	250g	250g	100g	280g	280g	560g	560g	210g(2000) 220g(2001)	220g
Accessories	Test leads	7066A	7066A	-	-	7066A	7066A	-	7066A	7066A 8216(1011)	7220A	7220A	-	-
	Fuse	8901x2	8923x2	-	-	-	8919x1	-	8923x1 8919x1	8918x1 8919x1	8926x1 8927x1	8926x1 8927x1	-	-
	Case	-	9013	9115(1018) 9114(1018H)	9188	-	9097	9130	-	-	-	-	-	-

*With wing-type holder

MULTIMETERS

KEW 1020R **NEW** / 1021R **NEW**



- Accurate reading with True RMS
- Large display with 6000 counts and Backlight
- MIN/MAX function
- Rugged and reliable
- Enhanced current measuring function using an external clamp sensor
- Sensor mode (with clamp sensor)
- Ergonomic design
- Safety Standard IEC61010-1 CAT IV 300V / CAT III 600V / CAT II 1000V (1020R only.)



photo : 1020R

photo : 1021R

	1020R	1021R
DC V	6.000/60.00/600.0/1000V(auto range) ±0.5%rdg±3dgt(6/60/600V) ±0.8%rdg±3dgt(1000V)	6.000/60.00/600.0V(auto range) ±0.5%rdg±3dgt
DC mV	600.0mV ±1.5%rdg±3dgt	
DC Clamp Sensor	60.00/200.0A(auto range) ±1.5%rdg±3dgt + Sensor accuracy	
AC V	6.000/60.00/600.0/1000V(auto range) ±1.0%rdg±3dgt [40 - 500Hz] (6/60/600V) ±1.3%rdg±3dgt [40 - 500Hz] (1000V)	6.000/60.00/600.0V(auto range) ±1.0%rdg±3dgt [40 - 500Hz]
AC mV	600.0mV ±2.0%rdg±3dgt [40 - 500Hz]	
AC Clamp Sensor	60.00/200.0A(auto range) ±2.0%rdg±3dgt + Sensor accuracy [40 - 500Hz]	
DC A	—	6.000/10.00A(auto range) ±1.5%rdg±3dgt
AC A	—	6.000/10.00A(auto range) ±1.5%rdg±3dgt [40 - 500Hz]
Ω	600.0Ω/6.000/60.00/600.0kΩ/6.000/40.00MΩ (auto range) ±0.5%rdg±5dgt(600Ω), ±0.5%rdg±2dgt(6/60/600kΩ), ±1.5%rdg±3dgt(40MΩ)	
Continuity buzzer	600Ω (Buzzer sounds below 90Ω)	
Diode test	Open-loop Voltage:<3.0V	
Capacitance	60.00/600.0nF/6.000/60.00/600.0/1000μF ±2.0%rdg±15dgt(60n/600nF), ±5%rdg±10dgt(6/60/600/1000μF)	
Frequency	ACV 99.99/999.9Hz/9.999/99.99kHz ±0.1%rdg±3dgt ACA 99.99/999.9Hz/9.999kHz ±0.1%rdg±3dgt*1	
DUTY	10.0 - 90.0% ±1.0%rdg±3dgt [50/60Hz]	
Applicable Standards	IEC 61010-1 CAT IV 300V / CAT III 600V / CAT II 1000V *2 Pollution degree 2, IEC 61010-2-033, IEC 61010-031 IEC 61326-2-2(EMC), IEC 60529 IP40, EN 50581(RoHS)	
Power source	R03(AAA)(1.5V) × 2	
Dimensions	155(L) × 75(W) × 40(D) mm (with Wing-type holder)	
Weight	250g approx. (including batteries and Wing-type holder)	
Accessories	Wing-type holder 7066A(Test leads) R03(AAA) × 2, Instruction manual	Wing-type holder, Flat-type holder, 7066A(Test leads) 8919(Ceramic fuse[10A/600V]) × 1(included), 9097(Carrying case), R03(AAA) × 2, Instruction manual
Optional Accessories	7234(Alligator clip), 8161(AC Clamp sensor), 8115(AC/DC Clamp sensor), 9189(Magnet hanger strap)	

*1 1021R only *2 1020R only



Magnet hanger strap for hands free operation

Accessories



wing-type Holder



MODEL 7066A
Test leads



Flat-type Holder

1021R Only



MODEL 8919
Fuse 10A/600V
(Included)



MODEL 9097
Carrying case

Optional Accessories



MODEL 7234
Alligator clip



KEW 8161
AC Clamp sensor

AC MAX 100A 024



MODEL 9189
Magnet hanger strap



KEW 8115
AC/DC Clamp sensor

AC MAX 130A 012 DC MAX 180A

MULTIMETERS



MODEL 1009

DC V AC V DC A AC A Ω \rightarrow \leftarrow Hz DUTY DATA HOLD REL AUTO POWER OFF

- Display : 4000 counts.
- Auto range and manual range selector provided. (with range hold feature)
- Resistance range provides audible continuity test.
- Automatically turns power off in about 30 minutes to conserve battery life.
- Direct current measurement up to 10A AC and DC.



KEW 1011/1012

1012 TRUE RMS DC V AC V DC A AC A Ω \rightarrow \leftarrow Hz DUTY $^{\circ}\text{C}$ DATA HOLD MAX/MIN REL AUTO POWER OFF

- 6040 counts with Bar Graph display
- MIN/MAX function enables to record min & max value
- REL(relative value) function
- Temperature measurement, selectable for $^{\circ}\text{C}$ and $^{\circ}\text{F}$ (KEW 1011)
- True RMS can measure and indicate distorted waveforms (KEW 1012)
- DUTY function



photo : 1012

	1009	1011	1012
DC V	400mV/4/40/400/600V $\pm 0.6\% \text{rdg} \pm 4 \text{dgt}^*$	600.0mV/6.000/60.00/600.0/600V $\pm 0.5\% \pm 2 \text{dgt}^*$	
AC V	400mV/4/40/400/600V $\pm 1.3\% \text{rdg} \pm 4 \text{dgt}^*$	6.000/60.00/600.0/600V $\pm 1.0\% \pm 3 \text{dgt}^*$	6.000/60.00/600.0/600V $\pm 1.2\% \pm 3 \text{dgt}^*$
DC A	400/4000 μA /40/400mA/4/10A $\pm 1.0\% \text{rdg} \pm 4 \text{dgt}^*$	600/6000 μA /60/600mA/6/10A $\pm 1.2\% \pm 3 \text{dgt}^*$	
AC A	400/4000 μA /40/400mA/4/10A $\pm 2.0\% \text{rdg} \pm 4 \text{dgt}^*$	600/6000 μA /60/600mA/6/10A $\pm 1.5\% \pm 4 \text{dgt}^*$	
Ω	400 Ω /4/40/400k Ω /4/40M Ω $\pm 1.0\% \text{rdg} \pm 4 \text{dgt}$	600 Ω /6/60/600k Ω /6/60M Ω $\pm 1.0\% \pm 2 \text{dgt}^*$	
Continuity buzzer	400 Ω (Buzzer sounds below 100 Ω)	0 - 600 Ω (Buzzer sounds below 100 Ω)	
Diode test	1.5V Release Voltage : Approx. 0.4mA test current	2.8V release voltage : Approx. 0.4mA test current	
Capacitance test	40/400nF/4/40/100 μF	40/400nF/4/40/4000 μF	
Frequency	5.12/51.2/512Hz/5.12/51.2/512kHz/5.12/10MHz	10/100/1000Hz/10/100/1000kHz/10MHz	
DUTY	0.1 - 99.9%(Pulse width/Pulse period) $\pm 2.5\% \pm 5 \text{dgt}$	0.1 - 99.9%(Pulse width/Pulse period) $\pm 2.0\% \pm 2 \text{dgt}$ (- 10kHz)	
Temperature	—	-50 - 300 $^{\circ}\text{C}$ (-58 - 572 $^{\circ}\text{F}$)(with the use of Temperature probe 8216)	—
Applicable Standards	IEC 61010-1 CAT III 300V, IEC 61326-1	IEC 61010-1 CAT III 300V, CAT II 600V, IEC 61326	
Power source	R6(AA)(1.5V) \times 2 (Auto power off : approx. 30 minutes)	R6(AA)(1.5V) \times 2 (Auto power off : approx. 15 minutes)	
Dimensions	161(L) \times 82(W) \times 50(D)mm	161(L) \times 82(W) \times 50(D)mm	
Weight	280g approx.	280g approx.	
Accessories	7066A(Test leads), 8919(Ceramic fuse[10A/600V]) \times 1, 8923(Ceramic fuse [0.5A/600V]) \times 1, R6(AA) \times 2, Instruction manual	7066A(Test leads), 8216(K-type temperature probe)(1011 Only), 8918(Ceramic fuse[0.8A/600V]) \times 1 built-in, 8919(Ceramic fuse[10A/600V]) \times 1 built-in, R6(AA) \times 2, Instruction manual	
Optional	7234(Alligator clip), 9095(Carrying case)		

*Basic accuracy : For the detailed accuracy, please see our product catalog on our website.



KEW 1109S

DC V AC V DC A AC A Ω dB

- Mirrored scale for easy and accurate reading.
- Output terminal to cut off DC component when measuring AC voltage.
- Safety designed input terminals and test leads.

	1109S
DC V	0.1/0.5/2.5/10/50/250/1000V(20k Ω /V) $\pm 3\%$ of FS
AC V	10/50/250/1000V(9k Ω /V) $\pm 3\%$ of FS
DC A	50 μA /2.5/25/250mA $\pm 3\%$ of FS
Ω	2/20k Ω /2/20M Ω $\pm 3\%$ of scale length
Decibel	-10 - +62dB
hFE	0 - 1000(Ω \times 10) $\pm 3\%$ of scale length
Power source	R6(AA)(1.5V) \times 2, 6F22(9V) \times 1
Dimensions	150(L) \times 100(W) \times 47(D)mm
Weight	330g approx.
Accessories	7066A(Test leads), 8901(Fuse[0.5A/250V]) \times 2, R6(AA) \times 2, 6F22 \times 1, Instruction manual
Optional	9168(Carrying case)



MODEL 1110

DC V AC V DC A AC A Ω \rightarrow \leftarrow $^{\circ}\text{C}$

- High sensitivity DC20k Ω /V.
- 1m drop-proof heavy duty designed taut-band movement.
- Can measure line voltage up to AC 600V. (Voltage to ground MAX AC 300V) (Protected by 600V ceramic fuse against accidental overload)
- Continuity buzzer, battery check, LED check, temperature measurement function.
- Skeleton type robust and clear case with carrying handle furnished as standard accessory.

	1110
DC V	0.3V(16.7k Ω /V) $\pm 3\%$ of FS 3/12/30/120/300/600V(20k Ω /V) $\pm 3\%$ of FS
AC V	12V(9k Ω /V) $\pm 4\%$ of FS 30/120/300/600V(9k Ω /V) $\pm 3\%$ of FS
DC A	60 μA /30/300mA $\pm 3\%$ of FS
Ω	3/30/300k Ω $\pm 3\%$ of scale length
Continuity buzzer	Buzzer sounds below 100 Ω
Battery Test	1.5V(0.7 - 2V) $\pm 3\%$ of FS (10 Ω load)
Temperature	-20 $^{\circ}\text{C}$ - +150 $^{\circ}\text{C}$ $\pm 3\%$ of scale length(0 $^{\circ}\text{C}$ - +100 $^{\circ}\text{C}$) $\pm 4\%$ of scale length(other ranges)
LED	10mA approx. at 0 Ω (at 3V of battery voltage)
Applicable Standards	IEC 61010-1 CAT III 300V /CAT II 600V, IEC 61326-1
Power source	R6(AA)(1.5V) \times 2
Dimensions	140(L) \times 94(W) \times 39(D)mm
Weight	280g approx.
Accessories	7066A(Test leads), 8923(Fuse[500mA/600V]) \times 2, R6(AA) \times 2, 9103(Carrying case), Instruction manual



DIGITAL MULTIMETERS

DIGITAL MULTIMETERS

KEW 1019R **NEW**

TRUE RMS DC AC V Ω ())) ← REL AUTO POWER SAVE



CE

- True-RMS Measurements.
- Large display.
- Sturdy measurement code.
- Simple range composition.
- Easy-to-use smart structure hard case.
- DCV, ACV, Ω capacitor Measurement.
- Complies with IEC 61010-1 CAT III 300V, CAT II 600V.

	1019R
DC V	600.0mV/6.000/60.00/600.0V(Input impedance :10MΩ) ±0.8%rdg±5dgt(600.0mV/6.000/60.00V) ±1.0%rdg±5dgt(600.0V)
AC V	6.000/60.00/600.0V(Input impedance:10MΩ) ±1.3%rdg±5dgt(6.000/60.00V)(50/60Hz) ±1.7%rdg±5dgt(6.000/60.00V)(45 - 500Hz) ±1.6%rdg±5dgt(600.0V)(50/60Hz) ±2.0%rdg±5dgt(600.0V)(45 - 500Hz)
Ω	600.0Ω/6.000/60.00/600.0kΩ/6.000/40.00MΩ ±1.0%rdg±5dgt(600.0Ω/6.000/60.00/600.0kΩ/6.000MΩ) ±2.5%rdg±5dgt(40.00MΩ)
Continuity buzzer	600Ω(Buzzer sounds below 60Ω)
Capacitance test	6.000/60.00/600.0nF/6.000/60.00/600.0μF ±3.5%rdg±5dgt(6.000nF) ±3.5%rdg±10dgt(60.00nF) ±3.5%rdg±5dgt(600.0nF/6.000/60.00μF) ±4.5%rdg±5dgt(600.0μF)
Applicable Standards	IEC 61010-1 CAT III 300V,CAT II 600V IEC 61010-2-033, IEC 61010-031, IEC 61326-2-2
Power source	CR2032(3V) × 1 (Auto power off : approx. 15 minutes)
Dimensions	126(L) × 85(W) × 18(D)mm (including hard case)
Weight	135g approx. (including battery and hard case)
Accessories	9188(Hard case), CR2032(3V) × 1, Instruction manual

Retractable Case Cover

2Way Test Probe Holder

Cap Holder

with Caps : CAT III
without Caps : CAT II

KEW 1018/1018H

DC AC V Ω ())) ← Hz DUTY DATA HOLD REL AUTO POWER OFF



CE

- Display : 4000 counts.
- Diode test feature.
- Continuity test.
- Auto range.
- Capacitance test feature.

	1018/1018H
DC V	400mV/4/40/400/600V(Input impedance 10MΩ) ±0.8%rdg±5dgt(400mV/4/40/400V) ±1.0%rdg±5dgt(600V)
AC V	4/40/400/600V(Input impedance 10MΩ) ±1.3%rdg±5dgt(4/40V) ±1.6%rdg±5dgt(400/600V)
Ω	400Ω/4/40/400kΩ/4/40MΩ ±1.0%rdg±5dgt(400Ω/4/40/400kΩ/4MΩ) ±2.5%rdg±5dgt(40MΩ)
Continuity buzzer	400Ω(Buzzer sounds below 120Ω)
Diode test	4V release voltage : Approx. 0.4mA test current
Capacitance test	4nF/40nF/400nF/4μF/40μF/200μF
Frequency	10/100Hz/1/10kHz (Input sensitivity Voltage:more than 1.5V)
Duty	0.1 - 99.9% ±2.5%rdg±5dgt(Pulse width/Pulse cycle)
Applicable Standards	IEC 61010-1 CAT III 300V, IEC 61010-031, IEC 61326-1
Power source	LR44(1.5V) × 2 (Auto power off : approx. 15 minutes)
Dimensions	107(L) × 54(W) × 10(D)mm
Weight	70g approx.
Accessories	9115(Carrying case[Soft]), 9114(Carrying case[Hard]), LR44× 2, Instruction manual

◀1018
Soft case type

◀1018H
Hard case type

KEW 1030

DC AC V Ω ())) ← Hz
DUTY DATA HOLD REL AUTO POWER OFF



CE

- Compact in Size, Light in Weight and Simple in Use
- Double moulding provides comfortable and good feeling in hand
- Penlight illuminates brightly the point to be measured, even in dark place
- Backlight LCD is highly visible, even in darkness
- Unique wrapping mechanism for test lead in the rear side compartment

	1030
DC V	400mV/4/40/400/600V(5 range auto) ±0.8%rdg±5dgt(400mV - 400V) ±1.0%rdg±5dgt(600V)
AC V	4/40/400/600V(4 range auto) ±1.3%rdg±5dgt(4/40V)(50/60Hz) ±1.6%rdg±5dgt(400/600V) (50/60Hz)
Ω	400/4k/40k/400k/4M/40MΩ(6 range auto) ±1.0%rdg±5dgt(400Ω - 4MΩ) ±2.5%rdg±5dgt(40MΩ)
Continuity buzzer	Buzzer sounds when resistance is 120Ω or less.
Diode test	Test voltage approx. 0.3 - 1.5V
Capacitance test	50n/500n/5μ /50μ /100μF(5 range auto) ±3.5%rdg±10dgt(50nF) ±3.5%rdg±5dgt(500n - 50μF) ±4.5%rdg±5dgt(100μF)
Frequency	5/50/500/5k/50k/200kHz ±0.1%rdg±5dgt
Duty	0.1 - 99.9% ±2.5%rdg±5dgt (Pulse width / Pulse cycle)
Applicable Standards	IEC 61010-1 CAT III 600V, IEC 61010-031, IEC 61326-1(EMC)
Power source	Button type battery LR44(SR44)(1.5V) × 2 (Auto power off : approx. 30 minutes)
Dimensions	190(L) × 39(W) × 31(D)mm
Weight	Approx. 100g (including batteries)
Accessories	9130(Carrying case), LR44(1.5V) × 2, Instruction manual

DIGITAL MULTIMETERS

KEWMATE 2012R



TRUE RMS Ø12 MAX 120A DC AC V DC AC A Ω Hz DATA HOLD AUTO POWER SAVE

- Innovative Multimeters with current measurements up to 120A AC/DC
- Unique Open Jaw technology for AC/DC current measurements
- Very compact and as reliable as a traditional full size multimeter

	2012R
DC V	600.0mV/6.000/60.00/600.0V (Input impedance: approx. 10MΩ) ±1.0%rdg±3dgt
AC V	6.000/60.00/600.0V (Input impedance: approx.10MΩ) ±1.5%rdg±5dgt (45 - 400Hz)
DC A	60.00/120.0A ±2.0%rdg±8dgt (60A) ±2.0%rdg±5dgt (120A)
AC A	60.00/120.0A ±2.0%rdg±5dgt (45 - 65Hz)
Ω	600.0Ω/6.000/60.00/600.0kΩ/6.000/60.00MΩ ±1.0%rdg±5dgt (600Ω/6/60/600kΩ) ±2.0%rdg±5dgt (6MΩ) ±3.0%rdg±5dgt (60MΩ)
Continuity buzzer	Buzzer sounds below 35±25Ω
Diode test	2V ±3.0%rdg±5dgt Open-loop voltage: approx. 2.7V
Capacitance	400.0nF/4.000/40.00µF ±2.5%rdg±10dgt
Frequency	AC A: 100/400Hz ±0.2%rdg±2dgt (100Hz) ±0.1%rdg±1dgt (100 - 400Hz) AC V: 100/1000Hz/10/100/300.0kHz ±0.2%rdg±2dgt (100Hz) ±0.1%rdg±1dgt (1000Hz/10/100/300.0kHz) (Input sensitivity Current: more than 6A Voltage: more than 6V [- 10kHz]/more than 20V [10k - 300kHz])
Conductor size	φ12mm max.
Applicable Standards	IEC 61010-1 CAT III 300V, CAT II 600V Pollution degree 2 IEC 61010-031, IEC 61010-2-032, IEC 61326
Power source	R03 (1.5V) × 2 *Continuous measuring time:DCV: approx. 150hours, ACA: approx. 25hours(Auto power save: approx. 15 minutes)
Dimensions	128 (L) × 92 (W) × 27 (D) mm
Weight	220g approx. (including batteries)
Accessories	R03 (1.5V) × 2, Instruction manual
Optional	9107 (Carrying case [Soft])

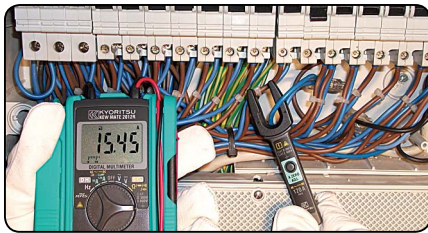

Measuring current in a Switchboard



Forklift maintenance

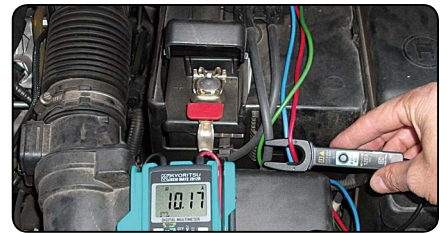

Automobile maintenance

MODEL 2000 / 2001

Ø6 MAX 60A / Ø10 MAX 100A

KEWMATE

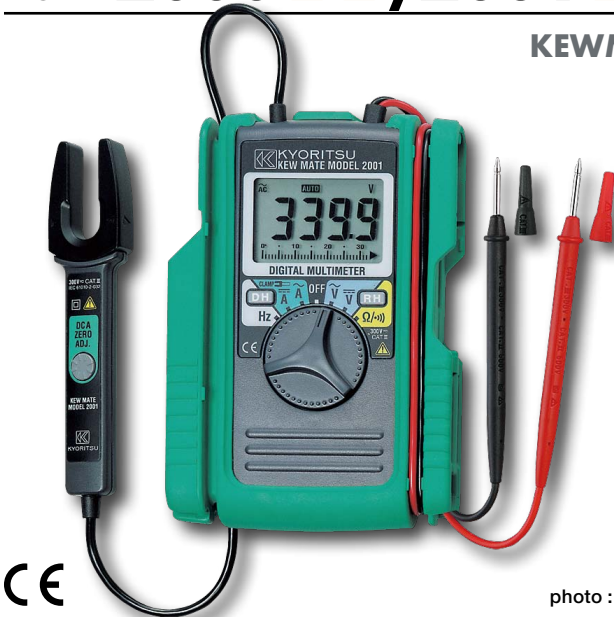

photo : 2001

DC AC V DC AC A Ω Hz DATA HOLD AUTO POWER SAVE

- Capable of measuring AC and DC currents up to 60A(MODEL 2000) /100A (MODEL 2001) with OPEN CLAMP SENSOR.
- 3400 counts with bargraph display.
- Pocket size and heavy duty design.
- Sleep function to save battery consumption.
- Designed to international safety standard IEC 61010-1 CAT III 300V

	2000	2001
DC V	340mV/3.4/34/340/600V (Input impedance : 10MΩ) ±1.5%rdg±4dgt	
AC V	3.4/34/340/600V (Input impedance : 10MΩ) ±1.5%rdg±5dgt[50 - 400Hz]	
DC A	60A ±2%rdg±5dgt	100A ±2%rdg±5dgt
AC A	60A ±2%rdg±5dgt(50/60Hz)	100A ±2%rdg±5dgt(50/60Hz)
Ω	340Ω/3.4/34/340kΩ/3.4/34MΩ ±1%rdg±3dgt(0 - 340kΩ) ±5%rdg±5dgt(3.4MΩ) ±15%rdg±5dgt (34MΩ)	
Continuity buzzer	Buzzer sounds below 30±10Ω (Continuity buzzer works on 340Ω range only)	
Frequency	(AC A)3.4/10kHz ±0.1%rdg±1dgt (AC V)3.4/34/300kHz ±0.1%rdg±1dgt (Input sensitivity Current:more than 15A Voltage:more than 30V)	(Input sensitivity Current:more than 25A Voltage:more than 30V)
Conductor size	φ6mm max.	φ10mm max.
Applicable Standards	IEC 61010-1 CAT III 300V Pollution degree 2 IEC 61010-031, IEC 61010-2-032, IEC 61326-1	
Power source	R03(DC1.5V) × 2 *Continuous measuring time : approx. 45 hours (Auto power save : approx. 10 minutes)	
Dimensions	128(L) × 87(W) × 24(D)mm	128(L) × 92(W) × 27(D)mm
Weight	210g approx.	220g approx.
Accessories	R03(1.5V) × 2 Instruction manual	
Optional	9107(Carrying case[Soft])	

DIGITAL MULTIMETERS

DIGITAL MULTIMETERS



photo : 1052

photo : 1062

KEW 1051/1052 KEW 1061/1062

True RMS CAT IV 600V DC AC V DC AC A 1061,1062 DC+AC Ω LP-Ω 1062 1062 Except for 1051 Hz DUTY °C dB DATA HOLD PEAK HOLD MAX/MIN AVG REL Filter
Except for 1051 USB AUTO POWER OFF

- True-RMS or MEAN value detection mode can be selected *only for 1052, 1062
- DC+AC TRMS Measurement *only for 1061, 1062
AC and DC values are displayed simultaneously via dual display.
- Fast Peak Hold response time of 250µs *only for 1062
- Low-pass filter *except for 1061
- Low Power-Ω measurements *only for 1062
- User calibration function

Safety design for industrial use

- Complies with IEC 61010-1 CAT IV 600V, CAT III 1000V
- Terminal shutter to prevent incorrect test leads' insertion in current terminals
- Very wide operating temperature range
From -20 to +55°C for 1061/1062
From -10 to +55°C for 1051/1052

Reliable support for data management

*except for 1051

- Large data internal memory
- Download data and Live Monitoring on a PC via the USB interface (Option for USB Communication set)

High Accuracy, High Performance and Reliable Measurements

- Top accuracy
0.02% basic DC accuracy for 1061/1062.
0.09% basic DC accuracy for 1051/1052.
- Dual display
1061/1062: 50,000 counts, Bar graph with 51 segments. White back light display.
1051/1052: 6,000 counts, Bar graph with 31 segments. Orange back light display.
- True-RMS Measurements
- Wide AC Frequency bandwidth from 10Hz to 100kHz *only for 1062

	1051	1052	1061	1062
Detection mode	RMS	MEAN/RMS (switch)	RMS	MEAN/RMS (switch)
DC V	600.0mV/6.000/60.00/600.0/1000V (Input impedance: 10MΩ [600mV/60/600/1000V], 11MΩ [6V]) ±0.09%rdg±2dgt *		50.000/500.00/2400.0mV/5.0000/50.000/500.00/1000.0V (Input impedance: Approx. 100MΩ [50/500/2400mV], 10MΩ [5/50/500/1000V]) ±0.02%rdg±2dgt *	
AC V [RMS]	600.0mV/6.000/60.00/600.0/1000V (Input impedance: 10MΩ<200pF [600mV], 11MΩ<50pF [6V], 10MΩ<50pF [60/600/1000V]) ±0.5%rdg±5dgt *		50.000*/500.00mV/5.0000/50.000/500.00/1000.0V (Input impedance: 11MΩ<50pF [50/500mV/5V], 10MΩ<50pF [50/500/1000V]) ±0.7%rdg±30dgt *	** 1062only ±0.4%rdg±30dgt *
AC V [MEAN]	-	600.0mV/6.000/60.00/600.0/1000V (Input impedance: 10MΩ<200pF [600mV], 11MΩ<50pF [6V], 10MΩ<50pF [60/600/1000V]) ±0.5%rdg±5dgt *	-	50.000/500.00mV/5.0000/50.000/500.00/1000.0V (Input impedance: 11MΩ<50pF [50/500mV/5V], 10MΩ<50pF [50/500/1000V]) ±1%rdg±30dgt *
DCV+ACV	-	-	5.0000/50.000/500.00/1000.0V (Input impedance: 11MΩ<50pF [5V], 10MΩ<50pF [50/500/1000V]) ±1%rdg±10dgt *	±0.5%rdg±10dgt *
DC A	600.0/6000µA/60.00/440.0mA/6.000/10.00A ±0.2%rdg±2dgt *		500.00/5000.0µA/50.000/500.00mA/5.0000/10.000A ±0.2%rdg±5dgt *	
AC A [RMS]	600.0/6000µA/60.00/440.0mA/6.000/10.00A ±0.75%rdg±5dgt *		500.00/5000.0µA/50.000/500.00mA/5.0000/10.000A ±1%rdg±20dgt *	±0.75%rdg±20dgt *
AC A [MEAN]	-	-	-	500.00/5000.0µA/50.000/500.00mA/5.0000/10.000A ±1.5%rdg±20dgt *
DCA+ACA	-	-	500.00/5000.0µA/50.000/500.00mA/5.0000/10.000A ±1.5%rdg±10dgt *	±1%rdg±10dgt *
Ω	600.0Ω/6.000/60.00/600.0kΩ/6.000/60.00MΩ ±0.4%rdg±1dgt *		500.00Ω/5.0000/50.000/500.00kΩ/5.0000/50.000MΩ ±0.1%rdg±2dgt *	±0.05%rdg±2dgt *
LowPower-Ω	-	-	-	5.000/50.00/500.0kΩ/5.000MΩ ±0.2%rdg±3dgt *
Continuity buzzer	600.0Ω (The buzzer turns on for resistances lower than 50±30Ω)		500.0Ω (The buzzer turns on for resistances lower than 100±50Ω)	
Diode test	2.000V ±1%rdg±2dgt Open circuit voltage: <3.5V (Approx. 0.5mA Measuring Current)		2.4000V ±1%rdg±2dgt Open circuit voltage: <5V (Approx. 0.5mA Measuring Current)	
Capacitance	10.00/100.0nF/1.000/10.00/100.0/1000µF ±2%rdg±5dgt *		5.000/50.00/500.0nF/5.000/50.00/500.0µF/5.000/50.00mF ±1%rdg±5dgt *	
Frequency	10.00 - 99.99/90.0 - 999.9Hz/0.900 - 9.999/9.00 - 99.99kHz ±0.02%rdg±1dgt *		2.000 - 9.999/9.00 - 99.99/90.0 - 999.9Hz/0.900 - 9.999/9.00 - 99.99kHz ±0.02%rdg±1dgt *	
DUTY	-	-	10 - 90% ±1%rdg	
Temperature	-50 - 600°C ±2%rdg±2°C (with the use of K-type Temperature probe)		-200 - 1372°C ±1%rdg±1.5°C (with the use of K-type Temperature probe)	
Applicable Standards	IEC 61010-1 CAT IV 600V, CAT III 1000V Pollution degree 2, IEC 61326-1 (EMC)			
Power source	R6 (1.5V)×4 (Auto power off: approx. 20 minutes)			
Dimensions	192(L)×90(W)×49(D) mm			
Weight	Approx. 560g (including batteries)			
Accessories	7220A (Test Leads), R6 × 4, 8926 (Fuse [440mA/1000V])×1 (included), 8927 (Fuse [10A/1000V])×1 (included), Instruction manual			

*Basic accuracy : For the detailed accuracy, please see our product catalog on our website.

DIGITAL MULTIMETERS

Reliable support for data management

※ except for 1051

Large internal memory to store test data

- KEW1062: 10,000 data in Logging mode, 100 data manually saved.
- KEW1061: 1,000 data in Logging mode, 100 data manually saved.
- KEW1052: 1,600 data in Logging mode, 100 data manually saved.
- Logging interval can set from 1 sec. to 30 min.

Test data can be transferred to a PC or directly to a Printer*

- Real-time data can be transferred and shown on a PC.
- Real-time transferring permits the saving of a considerable amount of data on a PC.
- Stored data of internal memory can be monitored by PC.

Data management with the software DMM Application*

- Stored data of internal memory can be monitored by PC.
- List of measured data can be converted into Graph.
- Data can be transferred to Excel** and saved as CSV file.

*Optional accessories are required.

**Excel is a registered trademark of Microsoft in the USA.

Data analysis with Excel

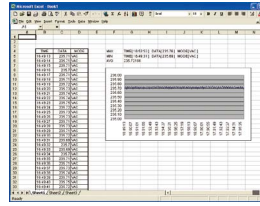

Printer output

L0000 N+12.539 VDC
L0001 N+12.532 VDC
L0002 N+12.532 VDC
L0003 N+12.529 VDC
L0004 N+12.532 VDC
L0005 N+12.538 VDC
L0006 N+12.541 VDC
L0007 N+12.546 VDC
L0008 N+12.552 VDC
L0009 N+12.557 VDC
L0010 N+12.555 VDC
L0011 N+12.554 VDC
L0012 N+12.553 VDC
L0013 N+12.553 VDC

- Printed items (from the left)
- L: Logging memory
 - 4 digit numbers: Data number
 - N: Normal measurement
 - (O: at "OL" display)
 - (B: at "Battery warning" display)
 - 5 digit numbers: Measurement
 - VDC: Unit (VDC is DC Voltage)



DMM Application software

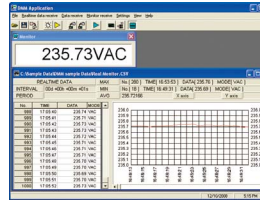

System requirements

- OS: Windows® Vista/7/8/10
- Display: XGA (Resolution 1024 x 768 dots) or more
- Hard-disk: Space required 10Mbyte or more
- Others: With CD-ROM drive and USB port

* Windows® is a registered trademark of Microsoft in the United States.

Optinal Accessories

Description	MODEL	Contents
Alligator Clip	7234	CAT IV 600V, CAT III 1000V 1set
USB Communication set	8241	USB adaptor+USB cable+DMM Software
Thermal paper for printer	8247	10 rolls
Thermocouple Type K	8405	-40°C - 500°C (Surface type, Point material: Ceramic)
	8406	-40°C - 500°C (Surface type)
	8407	-40°C - 700°C (Liquid, Semi-solid)
	8408	-40°C - 600°C (Air, Gas)
Clamp sensor	8115	Surface type
	8121	AC 100A
	8122	AC 500A
	8123	AC 1000A
	8146	AC 30A
	8147	AC 70A
Banana φ4mm Adjuster Plug	7146	length :190mm
Carrying case	9154	Soft case(for the main unit with test leads and communication cable)

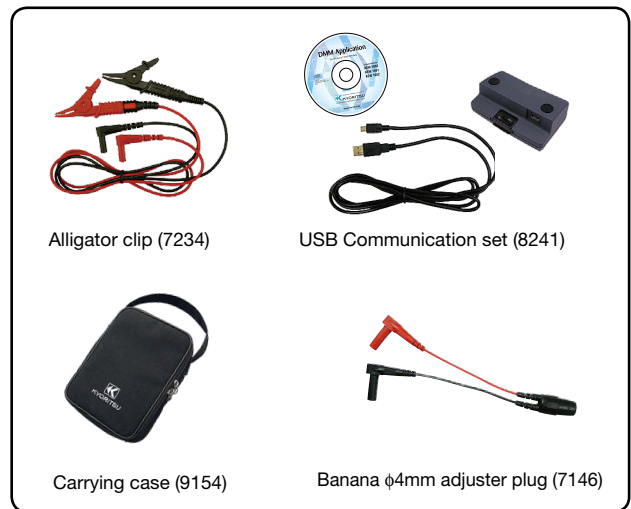

Thermocouple Type K Specification

MODEL	Usage	Measurement temperature	Tolerance (t: measurement temperature)	Response speed
8405	(Surface type, Point material: Ceramic)	-40°C - 500°C	±2.5°C/t = -40°C - 333°C, ±0.0075 × t °C/t = 333°C - 500°C	approx. 1.8 Sec.
8406	Surface type			approx. 1.0 Sec.
8407	(Liquid, Semi-solid)	-40°C - 700°C	±2.5°C/t = -40°C - 333°C, ±0.0075 × t °C/t = 333°C - 700°C	1 Sec. or less
8408	(Air, Gas)	-40°C - 600°C	±2.5°C/t = -40°C - 333°C, ±0.0075 × t °C/t = 333°C - 600°C	0.4 Sec.

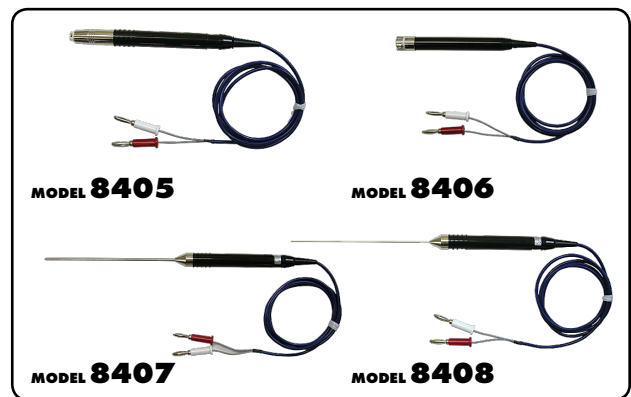

Clamp sensor Specification

	AC/DC current sensor		AC current sensor				Leakage & AC current sensor	
	8115	8121	8122	8123	8146	8147	8148	
Appearance								
Conductor size	φ12mm	φ24mm	φ40mm	φ55mm	φ24mm	φ40mm	φ68mm	
Rated current	Surface type	AC 100A	AC 500A	AC 1000A	AC 30A	AC 70A	AC 100A	
Output voltage	(Liquid, Semi-solid)	AC 500mV/100A	AC 500mV/500A	AC 500mV/1000A	AC 1500mV/30A	AC 3500mV/70A	AC 5000mV/100A	
Accuracy (50/60Hz)	AC ±1.0%rdg±0.4mV DC ±1.0%rdg±0.4mV (This accuracy is defined after a zero-adjustment)	±2.0%rdg±0.3mV			0 - 15A ±1.0%rdg±0.1mV 15 - 30A ±5.0%rdg	0 - 40A ±1.0%rdg±0.1mV 40 - 70A ±5.0%rdg	0 - 80A ±1.0%rdg±0.1mV 80 - 100A ±5.0%rdg	
Frequency range	40Hz - 1kHz							
Dimensions	127(L)×42(W)×22(D)mm	97(L)×59(W)×26(D)mm	128(L)×81(W)×36(D)mm	170(L)×105(W)×48(D)mm	100(L)×60(W)×26(D)mm	128(L)×81(W)×36(D)mm	186(L)×129(W)×53(D)mm	
Weight	approx. 160g	approx. 150g	approx. 260g	approx. 360g	approx. 150g	approx. 240g	approx. 510g	

CLAMP METERS

CLAMP METERS



CLAMP METERS

Selection Guide of Clamp Meters

		AC Clamp Meters											Fork Current Tester
		2608A	2031	2007R	2117R	2127R	2200	2200R	2002PA	2002R	2204R	2210R	2300R
Appearance													
Conductor size	Φ	$\phi 33\text{mm}$	$\phi 24\text{mm}$	$\phi 33\text{mm}$	$\phi 33\text{mm}$	$\phi 33\text{mm}$	$\phi 33\text{mm}$	$\phi 33\text{mm}$	$\phi 55\text{mm}$	$\phi 55\text{mm}$	$\phi 70\text{mm}$	$\phi 150\text{mm}$	$\phi 10\text{mm}$
Display		Analogue	Digital	Digital	Digital	Digital	Digital	Digital	Digital	Digital	Digital	Digital	Digital
Detection method		-	-	✓	✓	✓	-	✓	-	✓	✓	✓	✓
Frequency response		50/60Hz	40 - 1kHz	40 - 400Hz	45 - 1kHz	45 - 1kHz	45 - 65Hz(ACA) 45 - 500Hz(ACV)	40 - 1kHz(ACA) 45 - 500Hz(ACV)	40 - 1kHz	40 - 1kHz	45 - 500Hz	45 - 500Hz	DC 50/60Hz
Measurement													
AC A	Max	300A	200A	1000A	1000A	1000A	1000A	1000A	2000A	2000A	400A	3000A	100A
	Resolution	0.2A	0.01A	0.1A	0.01A	0.01A	0.01A	0.01A	0.1A	0.1A	0.001A	0.01A	0.1A
	Accuracy	±3% of FS	±2%R±5D	±1.5%R±4D	±1.5%R±4D	±1.5%R±4D	±1.4%R±6D	±1.5%R±5D	±1%R±3D	±1.5%R±3D	±3%R±5D	±3%R±5D	±2%R±5D
DC A	Max	-	-	-	-	-	-	-	-	-	-	-	100A
	Resolution	-	-	-	-	-	-	-	-	-	-	-	0.1A
	Accuracy	-	-	-	-	-	-	-	-	-	-	-	±2%R±5D
AC Voltage	AC V	600V	-	600V	60/600V	60/600V	600V	600V	750V	750V	-	-	-
DC Voltage	DC V	60V	-	600V	60/600V	60/600V	600V	600V	1000V	1000V	-	-	-
Resistance	Ω	10K Ω	-	✓	✓	✓	40M Ω	40M Ω	400K Ω	400K Ω	-	-	-
Continuity buzzer		-	-	✓	✓	✓	✓	✓	✓	✓	-	-	-
Frequency	Hz	-	-	-	-	-	-	-	-	-	-	-	-
Duty cycle ratio	DUTY	-	-	-	-	-	-	-	-	-	-	-	-
Diode test		-	-	-	-	✓	-	-	-	-	-	-	-
Capacitance		-	-	-	-	✓	-	-	-	-	-	-	-
Temperature	$^{\circ}\text{C}$	✓	-	-	-	-	-	-	-	-	-	-	-
Function													
Non contact voltage	NCV	-	-	-	✓	✓	-	-	-	-	-	-	✓
Back light		-	-	-	-	✓	-	-	-	-	-	✓	-
Data hold	DATA HOLD	✓	✓	✓	✓	✓	✓	✓	✓	✓	-	✓	✓
Peak hold	PEAK HOLD	-	-	-	-	✓	-	-	✓	✓	-	-	-
Max/Min	MAX/MIN	-	-	-	-	-	-	-	-	-	✓	✓	-
Relative	REL	-	-	-	-	-	-	-	-	-	-	-	-
Output	OUT PUT	-	-	-	-	-	-	-	✓	✓	-	-	-
Other													
Operating temperature		0 - 40 $^{\circ}\text{C}$	0 - 40 $^{\circ}\text{C}$	0 - 40 $^{\circ}\text{C}$	0 - 40 $^{\circ}\text{C}$	0 - 40 $^{\circ}\text{C}$	0 - 40 $^{\circ}\text{C}$	0 - 40 $^{\circ}\text{C}$	0 - 40 $^{\circ}\text{C}$	0 - 40 $^{\circ}\text{C}$	-10 - 50 $^{\circ}\text{C}$	0 - 50 $^{\circ}\text{C}$	0 - 40 $^{\circ}\text{C}$
Measurement categories		CAT III 300V CAT II 600V	CAT III 300V	CAT IV 300V CAT III 600V	CAT IV 300V CAT III 600V	CAT IV 300V CAT III 600V	CAT III 600V(ACA) CAT III 300V(AC/DCV) CAT II 600V(AC/DCV)	CAT IV 300V(ACA) CAT III 600V(ACA) CAT III 300V(AC/DCV) CAT II 600V(AC/DCV)	CAT III 600V CAT II 1000V	CAT III 600V CAT II 1000V	CAT IV 600V CAT III 1000V	CAT IV 600V CAT III 1000V	CAT III 300V
Power source		R6 x 1	LR-44 x 2	R03/LR03 x 2	R03/LR03 x 2	R03/LR03 x 2	R03/LR03 x 2	R03/LR03 x 2	R6 x 2	R6 x 2	R03/LR03 x 2	R03/LR03 x 2	R03 x 2
Dimensions (L)x(W)x(D)mm		193x78x39	147x58.5x26	204x81x36	204x81x36	204x81x36	190x68x20	190x68x20	247x105x49	247x105x49	120x70x26	120x70x26	161x40x30
Weight(Approx.)		275g	100g	220g	220g	220g	120g	120g	470g	470g	470g	300g	110g
Accessories	Test leads	7066A	-	7066A	7066A	7066A	7107A	7107A	7107A	7107A	-	-	-
	Fuse	8923x2	-	-	-	-	-	-	-	-	-	-	-
	Case	9097	9090	9079	9079	9079	9160	9160	9094	9094	9174	9174	9113

CLAMP METERS

Selection Guide of Clamp Meters

	DC Milliamp Clamp Meter/ Clamp Logger		AC/DC Clamp Meters							Leakage Clamp Meters				
	2500	2510	2010	2033	2046R	2055 2056R	2003A	2009R	2431	2434	2432	2433 2433R	2413F 2413R	
Appearance														
Conductor size	φ6 mm	φ6 mm	φ7.5mm	φ24mm	φ33mm	φ40mm	φ55mm	φ55mm	φ24mm	φ28mm	φ40mm	φ40mm	φ68mm	
Display	Digital	Digital	Digital	Digital	Digital	Digital	Digital	Digital	Digital	Digital	Digital	Digital	Digital	
Detection method	-	-	-	-	✓	✓ (2056R)	-	✓	-	-	-	✓ (2433R)	✓ (2413R)	
Frequency response	DC	DC	DC 40 - 2kHz	DC 20 - 1kHz	DC 40 - 400Hz	DC 40 - 400Hz	DC 40 - 1kHz	DC 20 - 1kHz	40 - 400Hz	40 - 400Hz	20 - 1kHz	20 - 1kHz	40 - 1kHz	
Measurement														
AC A	Max	-	-	20A	300A	600A	1000A	2000A	2000A	200A	100A	100A	400A	1000A
	Resolution	-	-	0.1mA	0.01A	0.1A	0.1A	0.1A	0.1A	0.01mA	0.1mA	0.001mA	0.01mA	0.1mA
	Accuracy	-	-	±1%R±2D	±1%R±4D	±2%R±5D	±2%R±5D	±1.5%R±2D	±1.3%R±3D	±2%R±4D	±2%R±4D	±1%R±5D	±1%R±5D	±1%R±5D ±1.8%R±5D(2413F)
DC A	Max	120mA	120mA	20A	300A	600A	1000A	2000A	2000A	-	-	-	-	-
	Resolution	0.01mA	0.01mA	0.001A	0.01A	0.1A	0.1A	0.1A	0.1A	-	-	-	-	-
	Accuracy	±0.2%R±5D	±0.2%R±5D	±1%R±2D	±1%R±4D	±1.5%R±5D	±1.5%R±5D	±1.5%R±2D	±1.3%R±2D	-	-	-	-	-
AC Voltage	AC V	-	-	-	-	600V	600V	750V	750V	-	-	-	-	-
DC Voltage	DC V	-	-	-	-	600V	600V	1000V	1000V	-	-	-	-	-
Resistance	Ω	-	-	-	-	60MΩ	60MΩ	4000Ω	4000Ω	-	-	-	-	-
Continuity buzzer		-	-	-	-	✓	✓	✓	✓	-	-	-	-	-
Frequency	Hz	-	-	-	-	10kHz	10kHz	-	10kHz	-	-	-	-	-
Duty cycle ratio	DUTY	-	-	-	-	✓	✓	-	-	-	-	-	-	-
Diode test		-	-	-	-	✓	✓	-	-	-	-	-	-	-
Capacitance		-	-	-	-	✓	✓	-	-	-	-	-	-	-
Temperature	°C	-	-	-	-	✓	✓ (2056R)	-	-	-	-	-	-	-
Function														
Non contact voltage	NCV	-	-	-	-	✓	✓	-	-	-	-	-	-	-
Back light		✓	✓	-	-	✓	✓	-	-	-	-	-	-	✓ (2413R)
Data hold	DATA HOLD	✓	✓	-	✓	✓	✓	✓	✓	✓	✓	✓	✓	✓
Peak hold	PEAK HOLD	-	-	-	-	✓	✓ (2056R)	✓ (Max)	✓*2	-	-	✓	✓	✓
Max/Min	MAX/MIN	-	-	-	-	✓	✓	-	-	-	-	-	-	-
Relative	REL	-	-	-	-	✓	✓	-	-	-	-	-	-	-
Output	OUT PUT	✓	✓	✓	-	-	-	✓	✓	-	-	-	-	✓
Filter	Filter	-	-	-	-	-	-	-	-	✓	✓	✓	✓	✓
Other														
Operating temperature		-10 - 50°C	-10 - 50°C	0 - 50°C	0 - 40°C	0 - 40°C	0 - 40°C	0 - 40°C	0 - 40°C	0 - 40°C	0 - 40°C	0 - 40°C	0 - 40°C	0 - 40°C
Measurement Categories		-	-	-	CAT III 300V	CAT IV 600V	CAT IV 600V	CAT IV 600V CAT III 1000V	CAT IV 600V CAT III 1000V	CAT III 300V	CAT III 300V	CAT III 300V	CAT III 300V	CAT III 300V
Power source		R6/LR6 x 4	R6/LR6 x 4 ¹	6LR61 x 1	LR-44 x 2	R03 x 2	R03 x 2	R6 x 2	R6 x 2	LR-44 x 2	R03 x 2	R03 x 2	R03 x 2	R03 x 2
Dimensions (L)x(W)x(D)mm		111x61x40 (Display unit) 104x34x20 (Sensor)	111x61x46 (Display unit) 104x33x20 (Sensor)	142x64x26 (Display unit) 153x23x18 (Sensor)	147x59x25	243x77x36	254x82x36	250x105x49	250x105x49	149x60x26	169x75x40	185x81x32	185x81x32	250x130x50
Weight(Approx.)		290g	310g	220g	100g	300g	310g	530g	540g	120g	220g	290g	270g	570g
Accessories	Test leads	-	-	-	-	7066A	7066A	7107A	7107A	-	-	-	-	-
	Case	9096	9096	9071	9090	9094	9094	9094	9094	9090	9097	9097	9097	9094

*1 External power is available.

*2 In the PEAK mode, the auto-ranging feature is disabled and measuring ranges are fixed as follows.

DC/ACA : 0 - 400.0A
DC/ACV : 0 - 400.0V

ANALOGUE/DIGITAL CLAMP METERS



CE

MODEL 2608A

Ø33 MAX 300A °C AC A DC AC V Ω

DATA HOLD

- DC voltage range is also available especially for checking emergency battery operated power supply.
- Can measure temperature using optional probe.
- Tear drop shaped transformer jaws for ease of use.

	2608A
AC A	6/15/60/150/300A ±3% of FS
AC V	150/300/600V ±3% of FS
DC V	60V ±3% of FS
Ω	1/10kΩ(25/250Ω mid-scale) ±2% of scale length
Temperature	-20°C - +150°C
Conductor size	φ33mm max.
Frequency response	50/60Hz
Applicable Standards	IEC 61010-1 CAT III 300V Pollution degree 2 IEC 61010-031, IEC 61010-2-032
Power source	R6(AA)(1.5V) × 1
Dimensions	193(L) × 78(W) × 39(D)mm
Weight	275g approx.
Accessories	7066A(Test leads), 8923(Fuse [0.5A/600V]) × 2 9097(Carrying case), R6(AA) × 1 Instruction manual



CE

KEW 2007R NEW

TRUE RMS Ø33 MAX 1000A AC A DC AC V Ω

DATA HOLD AUTO POWER SAVE

- Fully Safety jaw.
- Ergonomic over-molded body gives convenient one-hand operation.
- Large easy-to-read display with 0.1 A resolution.
- Accurate reading with True RMS 600/1000A auto-ranging.
- Long battery life.
- Safety Standard IEC61010-1 CAT IV 300V / CAT III 600V.

	2007R
AC A	600.0/1000A(Auto-ranging) ±1.5%rdg±4dgt[45 - 65Hz] ±2.0%rdg±4dgt[40 - 400Hz]
AC V	600.0V ±1.2%rdg±3dgt[45 - 65Hz] ±1.5%rdg±4dgt[40 - 400Hz]
DC V	600.0V ±1.2%rdg±3dgt
Ω	600.0Ω/6,000kΩ(Auto-ranging) ±1.3%rdg±5dgt[600Ω] ±2.0%rdg±3dgt[6.000kΩ]
Continuity buzzer	600Ω(Buzzer sounds below 90Ω)
Conductor size	φ33mm max.
Applicable Standards	IEC 61010-1 CAT IV 300V, CAT III 600V Pollution degree 2 IEC 61010-031, IEC 61010-2-032, IEC 61010-2-033 IEC 61326-2-2(EMC), IEC 61529 IP40, EN 50581(RoHS)
Power source	R03/LR03(AAA)(1.5V) × 2 *Continuous measuring time : approx. 170 hours (when R03 is used) (Auto power save : approx. 10 minutes)
Dimensions	204(L) × 81(W) × 36(D)mm
Weight	220g approx. (including batteries)
Accessories	7066A(Test leads), 9097(Carrying case) R03(AAA) × 2, Instruction manual

MODEL 2002PA/2002R

2002R TRUE RMS Ø55 MAX 2000A 10ms AC A DC AC V Ω

DATA HOLD PEAK HOLD OUT PUT AUTO POWER SAVE

- Can measure large AC current up to 2000A.
- Peak hold function.
- 55mm-dia large tear drop shaped jaws.

CE



photo : 2002R

	2002PA	2002R
AC A	400A(0 - 400A) ±1%rdg±3dgt[50/60Hz] ±2%rdg±3dgt[40Hz - 1kHz] 2000A(0 - 1500A) ±1%rdg±3dgt[50/60Hz] ±3%rdg±3dgt[40Hz - 1kHz] 2000A(1500 - 2000A) ±3.0%rdg[50/60Hz]	400A(0 - 400A) ±1.5%rdg±3dgt[45 - 65Hz] ±2.5%rdg±3dgt[40Hz - 1kHz] 2000A(0 - 1500A) ±2%rdg±5dgt[45 - 65Hz] ±3%rdg±5dgt[40Hz - 1kHz] 2000A(1501 - 2000A) ±4%rdg[50/60Hz]
AC V	40/400/750V ±1%rdg±2dgt[50/60Hz] ±1.5%rdg±3dgt[40Hz - 1kHz]	40/400/750V ±1%rdg±2dgt[45 - 65Hz] ±1.5%rdg±3dgt[40Hz - 1kHz]
DC V	40/400/1000V ±1%rdg±2dgt	
Continuity buzzer	buzzer sounds below 50±35Ω	
Ω	400Ω/4k/40k/400kΩ ±1.5%rdg±2dgt	
Conductor size	φ55mm max.	
Frequency response	40Hz - 1kHz	
Output	Recorder:DC400mV against AC400A DC200mV against AC2000A	
Applicable Standards	IEC 61010-1 CAT III 600V, CAT II 1000V IEC 61010-031 IEC 61010-2-032 IEC 61326-1	
Power source	R6(AA)(1.5V) × 2 *Continuous measuring time : approx. 150 hours (2002PA) *Continuous measuring time : approx. 80 hours (2002R) (Auto power save : approx. 10 minutes)	
Dimensions	247(L) × 105(W) × 49(D)mm	
Weight	470g approx.	
Accessories	7107A(Test leads), 8201(Output plug), 9094(Carrying case) R6(AA) × 2, Instruction manual	
Optional	7256(Output cord)	

DIGITAL CLAMP METERS AC



MODEL 2031

Ø24 MAX 200A AC A DATA HOLD AUTO POWER OFF

- Can measure large AC current up to 200A.
- 24mm-dia tear drop shaped jaws.



	2031
AC A	20A ±2%rdg±5dgt[50Hz - 1kHz] 200A ±2%rdg±5dgt[50/60Hz] ±3%rdg±10dgt[40Hz - 1kHz]
Conductor size	φ24mm max.
Frequency response	40Hz - 1kHz
Applicable Standards	IEC 61010-1 CAT III 300V
Power source	LR-44(1.5V) × 2 *Continuous measuring time : approx. 100 hours (Auto power off : approx. 10 minutes)
Dimensions	147(L) × 58.5(W) × 26(D)mm
Weight	100g Approx.
Accessories	9090 (Carrying case) LR-44 × 2 Instruction manual



KEW 2117R NEW

TRUE RMS Ø33 MAX 1000A AC A DC AC V Ω

NCV DATA HOLD AUTO POWER SAVE

- Fully Safety jaw
- Ergonomic over-molded body gives convenient one-hand operation
- Large easy-to-read display with 0.01 A resolution
- Accurate reading with True RMS 60/600/1000A auto-ranging
- Long battery life
- Safety Standard IEC61010-1 CAT IV 300V / CAT III 600V



	2117R
AC A	60.00/600.0/1000A (Auto-ranging) ±1.5%rdg±4dgt [45 - 65Hz] ±2.0%rdg±5dgt [40 - 1kHz]
AC V	60.00/600.0V (Auto-ranging) ±1.0%rdg±2dgt [45 - 65Hz] (600V) ±1.5%rdg±4dgt [40 - 1kHz] (60/600V)
DC V	60.00/600.0V (Auto-ranging) ±1.0%rdg±3dgt (60V) ±1.2%rdg±3dgt (600V)
Ω	600.0Ω/6.000/60.00/600.0kΩ (Auto-ranging) ±1.0%rdg±5dgt (600Ω) ±2.0%rdg±3dgt (6/60/600kΩ)
Continuity buzzer	600Ω (Buzzer sounds below 90Ω)
Conductor size	φ33mm max.
Applicable Standards	IEC 61010-1 CAT IV 300V, CAT III 600V Pollution degree 2 IEC 61010-031, IEC 61010-2-032, IEC 61010-2-033, IEC 61326-2-2(EMC), IEC 60529 IP40, EN 50581(RoHS)
Power source	R03/LR03(AAA)(1.5V)×2 *Continuous measuring time : approx. 170 hours (NCV_LED:off)(Auto power save : approx.10 minutes)
Dimensions	204(L) × 81(W) × 36(D)mm
Weight	220g Approx. (including batteries)
Accessories	7066A (Test leads), 9079 (Carrying case), R03(AAA)×2, Instruction manual



KEW 2127R NEW

TRUE RMS Ø33 MAX 1000A AC A DC AC V Ω

NCV DATA HOLD

10ms PEAK HOLD AUTO POWER SAVE

- 1000A AC Clamp Meter, AC60/600/1000A Auto Range
- True-RMS
- Peak Hold for inrush current
- 6000 counts display with Backlight
- Ø33mm Tear Drop shaped jaw easy to use in tight places
- Double molding gives comfortable feeling
- Safety standard IEC 61010-1, CAT IV 300V / CAT III 600V



	2127R
AC A	60.00/600.0/1000A (Auto-ranging) ±1.5%rdg±4dgt [45 - 65Hz] ±2.0%rdg±5dgt [40 - 1kHz]
AC V	60.00/600.0V (Auto-ranging) ±1.0%rdg±2dgt [45 - 65Hz] (600V) ±1.5%rdg±4dgt [40 - 1kHz] (60/600V)
DC V	60.00/600.0V (Auto-ranging) ±1.0%rdg±3dgt (60V) ±1.2%rdg±3dgt (600V)
Ω	600.0Ω/6.000/60.00/600.0kΩ/6.000/40.00MΩ(Auto-ranging) ±1.0%rdg±5dgt (600Ω) ±2.0%rdg±3dgt (6/60/600kΩ) ±3.0%rdg±3dgt (6MΩ) ±5.0%rdg±3dgt (40MΩ)
Continuity buzzer	600Ω (Buzzer sounds below 90Ω)
Capacitance test	1.000/10.00/100.0μF
Conductor size	φ33mm max.
Applicable Standards	IEC 61010-1 CAT IV 300V, CAT III 600V Pollution degree 2 IEC 61010-031, IEC 61010-2-032, IEC 61010-2-033, IEC 61326-2-2(EMC), IEC 60529 IP40, EN 50581(RoHS)
Power source	R03/LR03(AAA)(1.5V)×2 *Continuous measuring time : approx. 170 hours (when R03 is used)(NCV_LED:off)(Auto power save : approx.10 minutes)
Dimensions	204(L) × 81(W) × 36(D)mm
Weight	220g Approx. (including batteries)
Accessories	7066A (Test leads), 9079 (Carrying case), R03(AAA)×2, Instruction manual

DIGITAL CLAMP METERS AC



KEW 2200/2200R NEW

2200R
TRUE RMS Ø33 MAX 1000A AC A DC AC V Ω
DATA HOLD AUTO POWER OFF

- Ultra Slim and lightweight Handy design
- φ33mm Tear Drop Jaw easy to use in tight places.
- 1000A AC Clamp Meter
- DMM function ACV, DCV, Ω, Continuity Buzzer.
- Fuseless electronic protection on Ω/→) up to 600V
- DMM function ACV, DCV, Ω, Continuity Buzzer.
- Safety Standard IEC 61010-1, 61010-2-032 CAT IV 300V* / CAT III 600V *2200R only

photo : 2200R

	2200	2200R
Detection method	Averaging value	RMS
AC A	40.00/400.0/1000A (Auto-ranging) ±1.4%rdg±6dgt(50/60Hz) ±1.6%rdg±6dgt(45 - 65Hz)	40.00/400.0/1000A (Auto-ranging) ±1.5%rdg±5dgt(45 - 65Hz) ±2.0%rdg±5dgt(40Hz - 1kHz)
AC V	4.000/40.00/400.0/600V (Auto-ranging) ±1.8%rdg±7dgt(45 - 65Hz) ±2.3%rdg±8dgt(65 - 500Hz)	
DC V	400.0mV/4.000/40.00/400.0/600V (Auto-ranging) ±1.0%rdg±3dgt* *400mV range is excluded	
Ω	400.0Ω/4.000/40.00/400.0kΩ/4.000/40.00MΩ (Auto-ranging) ±2.0%rdg±4dgt(0 - 400kΩ) ±4.0%rdg±4dgt(4MΩ) ±8.0%rdg±4dgt(40MΩ)	
Continuity buzzer	buzzer sounds below 50±30Ω	
Conductor size	φ33mm max.	
Applicable Standards	IEC 61010-1 CAT IV 300V*, CAT III 600V Pollution degree2(AC A) *2200R only CAT III 300V, CAT II 600V Pollution degree2(AC/DC V) IEC 61010-031, IEC 61010-2-032, IEC 61326(EMC)	
Power source	R03/LR03(AAA) (1.5V) × 2	
Continuous measuring time	Approx. 350 hours	Approx. 120 hours
	Auto power off : approx. 10 minutes	
Dimensions	190(L) × 68(W) × 20(D)mm	
Weight	Approx. 120g(including batteries)	
Accessories	7107A (Test leads), 9160 (Carrying case), R03(AAA)×2, Instruction manual	

KEW 2204R NEW

TRUE RMS CAT IV 600V Ø70 MAX 400A AC A ☀
DATA HOLD MAX/MIN AUTO POWER OFF

- Flexible and light weight clamp sensor
- True RMS
- MIN / MAX function
- Backlight LCD display
- IEC 61010-1 (CAT IV 600V / CAT III 1000V)

	2204R
AC A (RMS)	
Range	4.000/40.00/400.0A
Accuracy	±3%rdg±5dgt[45-500Hz] (At the center of the circle formed by the flexible sensor)
Crest factor	Full scale CF<1.6, half scale<3.2 Effective input crest values are √2 times of the max values of each range.
Conductor size	φ70mm max.
Influence of Conductor position	Additional ±2%(max.) depending on the distance from the center position
Applicable Standards	IEC 61010-1, IEC 61010-2-032 CAT IV 600V / CAT III 1000V Pollution degree 2 IEC 61326-1(EMC), IEC 60529 IP40, EN50581(RoHS)
Operating temperature & humidity	0 - +50°C, less than 80% RH (without condensation)
Storage temperature & humidity	-10 - +60°C, less than 70% RH (without condensation)
Power source	R03 / LR03(AAA)(1.5V) × 2 *Continuous measuring time : approx. 120 hours (Auto power off : approx. 15 minutes)
Dimensions	120(L) × 70(W) × 26(D) mm : Display unit 1.8m : Sensor cable
Weight	200g Approx. (including batteries)
Accessories	9174 (Carrying case), LR03(AAA)×2, Instruction manual

KEW 2210R NEW

TRUE RMS CAT IV 600V Ø150 MAX 3000A AC A ☀
DATA HOLD MAX/MIN AUTO POWER OFF

- Flexible and light weight clamp sensor
- Wide reading range up to 3000A
- True RMS
- MIN / MAX function
- Backlight LCD display
- IEC 61010-1 (CAT IV 600V / CAT III 1000V)

	2210R
AC A (RMS)	
Range	30.00/300.0/3000A
Accuracy	±3%rdg±5dgt [45 - 500Hz] (At the center of the circle formed by the flexible sensor)
Crest factor	Full scale CF<1.6, half scale<3.2 Effective input crest values are √2 times of the max values of each range.
Conductor size	φ150mm max.
Influence of Conductor position	Additional ±3% (max.) depending on the distance from the center position
Overload protection	5000A AC for 10 seconds
Applicable Standards	IEC 61010-1, IEC 61010-2-030 CAT IV 600V / CAT III 1000V Pollution degree 2 IEC 61010-2-032, IEC 61326-1 (EMC), IEC 60529 IP40
Operating temperature & humidity	0 - +50°C, less than 80% RH (without condensation)
Storage temperature & humidity	-10 - +60°C, less than 70% RH (without condensation)
Power source	R03 / LR03 (AAA) (1.5V) × 2 *Continuous measuring time: approx. 120hours (Auto power off: approx. 15 minutes)
Dimensions	120 (L) × 70 (W) × 26 (D) mm : Display unit 1.8m : Sensor cable
Weight	Approx. 300g (including batteries)
Accessories	9174 (Carrying case), LR03 (AAA) × 2, Instruction manual

DIGITAL CLAMP METERS AC/DC

DIGITAL CLAMP METERS AC/DC



CE

KEW 2003A

CAT IV 600V Ø55 MAX 2000A DC AC A DC AC V Ω
400ms

DATA HOLD PEAK HOLD OUT PUT AUTO POWER SAVE

- Equipped to measure both AC and DC current with transformer jaws of large diameter.
- Can measure AC and DC currents up to 2000A.
- Output terminal for connection to recorders.
- AC/DC voltage, resistance measurement and continuity functions also available.

	2003A
AC A	400A/2000A(0 - 1000A) ±1.5%rdg±2dgt[50/60Hz] ±3%rdg±4dgt[40 - 500Hz] ±5%rdg±4dgt[500Hz - 1kHz] 2000A(1001 - 2000A) ±3%rdg±2dgt[50/60Hz]
DC A	400/2000A ±1.5%rdg±2dgt
AC V	400/750V ±1.5%rdg±2dgt[50/60Hz] ±1.5%rdg±4dgt[40Hz - 1kHz]
DC V	400/1000V ±1%rdg±2dgt
Ω	400/4000Ω ±1.5%rdg±2dgt
Continuity buzzer	buzzer sounds below 50±35Ω
Conductor size	φ55mm max.
Frequency response	40Hz - 1kHz
Output	Recorder: DC400mV against AC/DC400A DC200mV against AC/DC2000A
Applicable Standards	IEC 61010-1 CAT IV 600V, CAT III 1000V IEC 61010-2-032
Power source	R6(AA)(1.5V) × 2 *Continuous measuring time : approx. 100 hours(Auto power save : approx. 10 minutes)
Dimensions	250(L) × 105(W) × 49(D)mm
Weight	530g approx.
Accessories	7107A(Test leads) 8201(Output plug) 9094(Carrying case) R6(AA) × 2 Instruction manual
Optional	7256(Output cord)



CE

KEW 2009R

TRUE RMS CAT IV 600V Ø55 MAX 2000A DC AC A DC AC V
10ms

Ω Hz DATA HOLD PEAK HOLD OUT PUT

AUTO POWER OFF

- True RMS reading instrument ideal for accurate measurement of distorted waveforms and non-sinusoidal waveforms arising from thyristors.
- Can measure AC and DC currents up to 2000A.
- Output terminal for connection to recorders.

	2009R
AC A	400.0/2000A ±1.3%rdg±3dgt(0 - 400A,150 - 1700A)(45 - 66Hz) ±2.0%rdg±5dgt(0 - 400A,150 - 1700A)(20Hz - 1kHz) ±2.3%rdg±3dgt(1701 - 2000A)(45 - 66Hz)
DC A	400.0/2000A ±1.3%rdg±2dgt
AC V	40.00/400.0/750V ±1.0%rdg±3dgt(45 - 66Hz) ±1.5%rdg±5dgt(20Hz - 1kHz)
DC V	40.00/400.0/1000V ±1.0%rdg±2dgt
Ω	400.0/4000Ω ±1.5%rdg±2dgt
Continuity buzzer	Buzzer sounds below 20Ω
Hz	10 - 4000Hz ±1.5%rdg±5dgt (Input sensitivity Current:more than 40A Voltage:more than 10V)
Output	Recorder: DC400mV against AC/DC400A DC200mV against AC/DC2000A
Conductor size	φ55mm max.
Applicable Standards	IEC 61010-1 CAT IV 600V, CAT III 1000V IEC 61010-2-032, IEC 61326-1, IEC 61326-2-1
Power source	R6 (1.5V) × 2 *Continuous measuring time: approx. 15 hours (Auto power off: approx. 10 minutes)
Dimensions	250 (L) × 105 (W) × 49 (D) mm
Weight	Approx. 540g(including batteries)
Accessories	7107A(Test leads) 8201(Output plug) 9094(Carrying case) R6(AA)(1.5V)×2, Instruction manual
Optional	7256(Output cord)



MODEL 2010

Ø7.5 MAX 20A DC AC A OUT PUT External Power Supply

- High sensitivity, miniature AC/DC clamp meter.
- 0.1mA minimum resolution for AC current and 1mA minimum resolution for DC current.
- Output terminal for recorder connection.

	2010
AC A	200mA/2/20A ±1%rdg±2dgt[50/60Hz](200mA) ±1.5%rdg±4dgt[40Hz - 2kHz](200mA) ±1%rdg±2dgt[50/60Hz](2A) ±2.5%rdg±5dgt[40Hz - 2kHz](2/20A)
DC A	2/20A ±1%rdg±2dgt(2A) ±1.5%rdg±4dgt(20A)
Conductor size	φ7.5mm max.
Frequency response	DC 40Hz - 2kHz
Output	Recorder: DC200mV against AC200mA/2/20A DC200mV against DC2/20A
Power source	6LR61(9V Alkaline battery) × 1 or AC adaptor *Continuous measuring time : approx. 20 hours (DC)/approx. 40 hours (AC)
Dimensions	142(L) × 64(W) × 26(D)mm : Display unit 153(L) × 23(W) × 18(D)mm : Sensor
Weight	220g approx.
Accessories	9071(Carrying Case) 6LR61 × 1 Instruction manual
Optional	7256(Output cord) 8022(AC adaptor)(110V) 8023(AC adaptor)(220V)

DIGITAL CLAMP METERS AC/DC



CE

MODEL 2033

Ø24 MAX 300A DC AC A DATA HOLD AUTO POWER SAVE

- Smallest clamp meter capable of AC and DC current measurements.
- 300A auto ranging has minimum resolution of 0.01A AC/DC.
- Auto-zero function to allow one touch zero adjustment.

	2033
AC A	40/300A ±1%rdg±4dgt[50/60Hz](0 - 40A) ±2.5%rdg±4dgt[20Hz - 1kHz](0 - 40A) ±1.5%rdg±4dgt[50/60Hz](20 - 200A) ±2.5%rdg±4dgt[20Hz - 1kHz](20 - 200A) ±3.5%rdg[50/60Hz](200 - 300A) ±4%rdg[20Hz - 1kHz](200 - 300A)
DC A	40/300A ±1%rdg±4dgt(0 - ±40A) ±1.5%rdg±4dgt(±20 - ±200A) ±3%rdg(±200 - ±300A)
Conductor size	φ24mm max.
Frequency response	DC 20Hz - 1kHz
Applicable Standards	IEC 61010-1 CAT III 300V IEC 61010-2-032
Power source	LR-44(1.5V) × 2 *Continuous measuring time : approx. 10 hours (Auto power save : approx. 5 minutes)
Dimensions	147(L) × 59(W) × 25(D)mm
Weight	100g approx.
Accessories	9090 (Carrying case) LR-44 × 2 Instruction manual



CE

KEW 2046R

THE RMS CAT IV 600V Ø33 MAX 600A DC AC V DC AC A
Ω Hz DUTY 10ms
°C NCV DATA HOLD PEAK HOLD MAX/MIN
REL AUTO POWER OFF

- Very useful for power distribution companies, power utilities and maintenance fields.
- Red LED, as "Non Contact Voltage" function, gives warning to the user on the presence of AC voltage.
- Double molding gives comfortable feeling in palm.
- 6039 counts with Bar Graph display.

	2046R
AC A	0 - 600.0A ±2.0%rdg±5dgt(50/60Hz) ±3.5%rdg±5dgt(40 - 500Hz)
DC A	0 - 600.0A ±1.5%rdg±5dgt
AC V	6/60/600V(Auto Ranging) ±1.5%rdg±4dgt(50/60Hz) ±3.5%rdg±5dgt(40 - 400Hz)
DC V	600m/6/60/600V(Auto Ranging) ±1.0%rdg±3dgt
Ω	600/6k/60k/600k/6M/60MΩ(Auto Ranging) ±1%rdg±5dgt(600 - 6M) / ±5%rdg±8dgt(60M)
Continuity buzzer	Buzzer Sounds at 100Ω
Hz	10/100/1k/10kHz(Auto Ranging) (Input sensitivity Current: more than 50A[- 1kHz] Voltage: more than 1V[- 10kHz])
DUTY	0.1 - 99.9% ±2.5%rdg ±5dgt (Pulse width/Pulse cycle)
Capacitance test	400n/4μ/40μF(Auto Ranging)
Temperature	-50°C - +300°C(with the use of Temperature probe 8216)
Conductor size	φ33
Applicable Standards	IEC 61010-1 CAT IV 600V IEC 61010-2-032, IEC 61326
Power source	R03 (1.5V)(AAA) × 2 *Continuous measuring time : approx. 10 hours (Auto power off : approx. 15 minutes)
Dimensions	243(L) × 77(W) × 36(D) mm
Weight	300g approx.
Accessories	7066A(Test leads) 9094(Carrying case) R03 × 2 Instruction manual
Optional	8216(Temperature probe)



CE

KEW 2055/2056R

2056R THE RMS CAT IV 600V Ø40 MAX 1000A DC AC V DC AC A 2056R
Ω Hz DUTY 10ms
°C NCV DATA HOLD PEAK HOLD MAX/MIN
REL 2055 AUTO POWER SAVE 2056R AUTO POWER OFF

- Very useful for power distribution companies, power utilities and maintenance fields.
- Red LED, as "Non Contact Voltage" function, gives warning to the user on the presence of AC voltage.
- Double molding gives comfortable feeling in palm.
- 6039 counts with Bar Graph display.

photo : 2056R

	2055	2056R
AC A	0 - 600.0/1000A ±1.5%rdg±5dgt(50/60Hz) ±3.0%rdg±5dgt(40 - 400Hz)	0 - 600.0/1000A ±2.0%rdg±5dgt(50/60Hz) ±3.5%rdg±5dgt(40 - 500Hz)
DC A	0 - 600.0/1000A ±1.5%rdg±5dgt	
AC V	6/60/600V(Auto Ranging) ±1.3%rdg±4dgt(50/60Hz) ±3.0%rdg±5dgt(40 - 400Hz)	6/60/600V(Auto Ranging) ±1.5%rdg±4dgt(50/60Hz) ±3.5%rdg±5dgt(40 - 400Hz)
DC V	600m/6/60/600V(Auto Ranging) ±1.0%rdg±3dgt	
Ω	600/6k/60k/600k/6M/60MΩ (Auto Ranging) ±1%rdg±5dgt(600 - 6M) / ±5%rdg±8dgt(60M)	
Continuity buzzer	Buzzer Sounds at 100Ω	
Capacitance test	-	400n/4μ/40μF(Auto Ranging)
Temperature	-	-50°C - +300°C (with the use of Temperature probe 8216)
Hz	10/100/1k/10kHz(Auto Ranging) (Input sensitivity Current: more than 50A[- 1kHz] Voltage: more than 1V[- 10kHz])	
DUTY	0.1 - 99.9% ±2.5%rdg ±5dgt (Pulse width/Pulse cycle)	
Conductor size	φ40	
Applicable Standards	IEC 61010-1 CAT IV 600V, IEC 61010-2-032, IEC 61326	
Power source	R03 (1.5V)(AAA) × 2 *Continuous measuring time : approx. 35 hours (Auto power save : approx. 15 minutes) (2055) *Continuous measuring time : approx. 10 hours (Auto power off : approx. 15 minutes) (2056R)	
Dimensions	254(L) × 82(W) × 36(D) mm	
Weight	310g approx.	
Accessories	7066A(Test leads) 9094(Carrying case) R03 × 2 Instruction manual	
Optional	-	8216(Temperature probe)

DC MILLIAMP CLAMP METER/CLAMP LOGGER

KEW **2500/2510** **NEW**

2510 2510
 Ø6 DC A DATA HOLD AUTO POWER OFF OUT PUT Bluetooth External Power Supply



photo : 2510

	2500	2510
DC A	20/100mA(Auto ranging) ±0.2%rdg±5dgt(0.00mA - 21.49mA) ±1.0%rdg±5dgt(21.0mA - 120.0mA)	
Conductor size	φ6mm max.	
Analog output	Recorder: DC1000mV against DC100mA	
Communication Interface	-	Bluetooth Ver2.1+EDR Class2
Applicable Standards	IEC 61010-1, Pollution degree 2 IEC 61010-2-032, IEC 61326-1(EMC) IEC 60529 IP40, EN50581(RoHS)	
Operating temperature & humidity	-10 - +50°C < 85%	
Storage temperature & humidity	-20 - +60°C < 85%	
Power source	R6/LR6(AA) (1.5V) × 4	R6/LR6(AA) (1.5V) × 4 (Alkaline LR6 is recommended.) External supply (AC adapter MODEL8320)
Battery life	Approx. 60 hours continuous (with Backlight and LED light OFF)	Approx. 50 hours continuous with alkaline batteries (with Backlight, LED light and Bluetoothfeature OFF)
Dimensions	111(L) × 61(W) × 40(D)mm : Display unit 104(L) × 34(W) × 20(D)mm : Sensor 700mm : Sensor cable	111(L) × 61(W) × 46(D)mm : Display unit 104(L) × 34(W) × 20(D)mm : Sensor 700mm : Sensor cable
Weight	Approx. 290g (including batteries)	Approx. 310g (including batteries)
Accessories	9096(Carrying case) LR6(AA) × 4 Instruction manual	8320(AC adapter) KEW Windows for 2510(Software) 9096(Carrying case) LR6(AA) × 4, Instruction manual Software installation manual
Optional	7256(Output cord)	



- 0.01mA resolution for DC current
- Top class measurement 0.2% accuracy
- Ø6mm clamp jaw easy to use in tight places
- Measurement from 0.01mA to 120.0mA
- Dual display with backlight shows both mA measurement and percent of 4-20 mA span
- Spotlight for illuminating measurement point
- Analog output terminal for recorder connection
- Memory function stores up to 192,000 records (2510 only).
- Transfer data to PC via Bluetooth (2510 only).

Analog output terminal for recorder connection

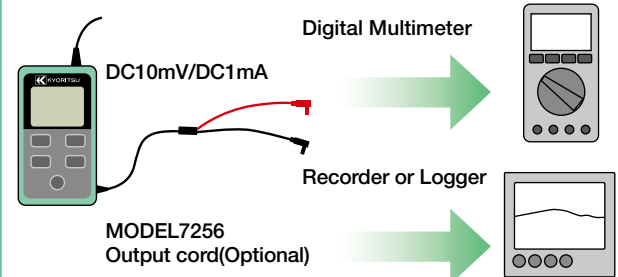

Note: The Auto-power OFF can be disabled for long recording

Memory function/Communication function (2510 Only)

Measured data can be transferred to a PC

Five selectable recording intervals

Memory capacity up to 192,000 data

Analyzing and processing the measured data with a PC

Recording interval	Max recording period
1 sec	53 hours
5 sec	11 days
10 sec	22 days
30 sec	66 days
60 sec	133 days

External supply

Bluetooth

OS : Windows®Vista/7/8/10
 Display : XGA(Resolution 1024×768 dots) or more
 HDD : Space required 1Gbyte or more
 Other : With CD-ROM drive , NET Framework (3.5 or more)

* Windows® is registered trademark of Microsoft in the United States.
 * Bluetooth® is a registered trademark of Bluetooth SIG.

Accessories

MODEL 9096
Carrying case

2510 only

MODEL 8320
AC adapter

Optional Accessory

MODEL 7256
Output cord

KEW windows for 2510

Diameter of measurable conductor : φ6mm max



Applicable to signal measurement on process and building instrumentation



Spotlight LED & Backlight Display



LEAKAGE CLAMP METERS



CE

MODEL 2431

Ø24 MAX 200A Resolution 0.01mA AC A DATA HOLD Filter

AUTO POWER OFF

- Frequency Selector Switch to eliminate the effect of harmonics.
- Auto power-off function
- Rotary switch for easy one finger power-on and range selection.

	2431
AC A (50/60Hz)	20/200mA/200A ±3%rdg±5dgt(20/200mA/100A) ±5%rdg±5dgt(200A)
AC A (WIDE)	20/200mA/200A ±2%rdg±4dgt[50/60Hz](20/200mA/0 - 100A) ±5%rdg±6dgt[40 - 400Hz](20/200mA/0 - 100A) ±5%rdg±4dgt[50/60Hz](100.1 - 200A)
Conductor size	φ24mm max.
Frequency response	40 - 400Hz
Effect of external stray magnetic field φ15mm 100A	10mA AC max.
Applicable Standards	IEC 61010-1 CAT III 300V IEC 61010-2-032
Power source	LR-44(1.5V) × 2 *Continuous measuring time : approx. 15 hours (Auto power off : approx. 10 minutes)
Dimensions	149(L)× 60(W) × 26(D)mm
Weight	120g approx.
Accessories	9090 (Carrying case) LR-44 × 2 Instruction manual



CE

MODEL 2432

High Sensitive Model

Ø40 MAX 100A Resolution 0.001mA AC A DATA HOLD PEAK HOLD

10ms

Filter

AUTO POWER OFF

- Frequency Selector Switch to eliminate the effect of harmonics.
- Three ranges: 4mA/40mA/100A.

	2432
AC A (50/60Hz)	4/40mA/100A ±1%rdg±5dgt(4/40mA) ±1%rdg±5dgt(0 - 80A) ±5%rdg(80.1 - 100A)
AC A (WIDE)	4/40mA/100A ±1%rdg±5dgt[50/60Hz] ±2.5%rdg±10dgt[20Hz - 1kHz](4/40mA) ±1%rdg±5dgt[50/60Hz] ±2.5%rdg±10dgt[40Hz - 1kHz](0 - 80A) ±5%rdg[50/60Hz] ±10%rdg[40Hz - 1kHz](80.1 - 100A)
Maximum circuit voltage	600V AC/DC (between line/neutral) 300V AC/DC (against earth)
Conductor size	φ40mm max.
Frequency response	20Hz - 1kHz(40Hz - 1kHz:100A)
Effect of external stray magnetic field	2mA AC approx. in proximity to a 15mm-dia conductor carrying 100A AC
Applicable Standards	IEC 61010-1 CAT III 300V Pollution degree 2 IEC 61010-2-032
Power source	R03(DC1.5V) × 2 *Continuous measuring time : approx. 40 hours (Auto power off : approx. 10 minutes)
Dimensions	185(L) × 81(W) × 32(D)mm
Weight	290g approx.
Accessories	9097(Carrying case) R03(1.5V) × 2 Instruction manual



CE

MODEL 2433/2433R

2433R TRUE RMS Ø40 MAX 400A Resolution 0.01mA AC A DATA HOLD

10ms

PEAK HOLD Filter

AUTO POWER OFF

- Frequency Selector Switch to eliminate the effect of harmonics.
- Three ranges: 40mA/400mA/400A.

	2433/2433R
AC A (50/60Hz)	40/400mA/400A ±1%rdg±5dgt(40/400mA) ±1%rdg±5dgt(0 - 350A:2433, 0 - 300A:2433R) ±2%rdg(350.1 - 399.9A:2433, 300.1 - 399.9A:2433R)
AC A (WIDE)	40/400mA/400A ±1%rdg±5dgt[50/60Hz] ±2.5%rdg±10dgt[20Hz - 1kHz](40/400mA) ±1%rdg±5dgt[50/60Hz] ±2.5%rdg±10dgt[40Hz - 1kHz](0 - 350A:2433, 0 - 300A:2433R) ±2%rdg[50/60Hz] ±5%rdg[40Hz - 1kHz](350.1 - 399.9A:2433, 300.1 - 399.9A:2433R)
Maximum circuit voltage	600V AC/DC (between line/neutral) 300V AC/DC (against earth)
Conductor size	φ40mm max.
Frequency response	20Hz - 1kHz(40Hz - 1kHz:400A)
Effect of external stray magnetic field	10mA AC approx. in proximity to a 15mm-dia conductor carrying 100A AC
Applicable Standards	IEC 61010-1 CAT III 300V Pollution degree 2 IEC 61010-2-032
Power source	R03 (DC1.5V) × 2 *Continuous measuring time : approx. 40 hours (2433) *Continuous measuring time : approx. 24 hours (2433R) (Auto power off : approx 10 minutes)
Dimensions	185(L) × 81(W) × 32(D)mm
Weight	270g approx.
Accessories	9097 (Carrying case) R03(1.5V) × 2 Instruction manual

photo : 2433R

LEAKAGE CLAMP METERS

KEW 2413F/2413R



2413R
 True RMS **Ø68** MAX 1000A AC A DATA HOLD PEAK HOLD
 Resolution 0.1mA OUTPUT Filter

- Large transformer jaws of 68mm diameter makes it possible to clamp on all three or four wires (3 phases) together for leakage current measurement.
- Frequency filter switch to eliminate the effect of the harmonics.
- 2 way analogue output terminal.

photo : 2413R

	2413F	2413R
AC A (50/60Hz)	200mA/2/20/200A/1000A ±1.5%rdg±2dgt(200mA/2/20A) ±2%rdg±2dgt(200A/0 - 500A) ±5.5%rdg(501 - 1000A)	200mA/2/20/200/1000A ±2.5%rdg±5dgt(200mA/2/20A) ±3.0%rdg±5dgt(200A/0 - 500A) ±5.5%rdg(501 - 1000A)
AC A (WIDE)	200mA/2/20/200A/1000A ±1%rdg±2dgt(50/60Hz) ±3%rdg±2dgt(40Hz - 1kHz)(200mA/2/20A) ±1.5%rdg±2dgt(50/60Hz) ±3.5%rdg±2dgt(40Hz - 1kHz)(200A/0 - 500A) ±5%rdg(50/60Hz) ±10%rdg(40Hz - 1kHz)(501 - 1000A)	200mA/2/20/200/1000A ±1.8%rdg±5dgt(50/60Hz) ±3.0%rdg±5dgt(40Hz - 1kHz)(200mA/2/20A) ±2.0%rdg±5dgt(50/60Hz) ±3.5%rdg±5dgt(40Hz - 1kHz)(200A/0 - 500A) ±5.0%rdg(50/60Hz)(501 - 1000A)
Conductor size	φ68mm max.	
Frequency response	40Hz - 1kHz	
Effect of external stray magnetic field φ15mm 100A	10mA AC max.	
Output	Waveform:AC200mV against the maximum value of each range (1000A range is 100mV) Recorder:DC200mV against the maximum value of each range (1000A range is 100mV)	
Crest factor	—	3.0 or Less
Applicable Standards	IEC 61010-1 CAT III 300V IEC 61010-2-032	
Power source	6F22(9V) × 1 *Continuous measuring time : approx. 60 hours	
Dimensions	250(L) × 130(W) × 50(D)mm	
Weight	570g approx.	600g approx.
Accessories	9094(Carrying case) 6F22 × 1	Instruction manual
Optional	7073(2WAY Output cord)	



MODEL 2434



Ø28 MAX 100A Resolution 0.1mA AC A DATA HOLD Filter
 AUTO POWER SAVE

- Least affected by external stray magnetic field.
- 20mA AC max. in proximity to a 15mm-dia conductor carrying 100A AC.
- Frequency Selector Switch to eliminate the effect of harmonics.

	2434
AC A (50/60Hz)	400mA/4/100A ±2%rdg±4dgt
AC A (WIDE)	400mA/4/100A ±2%rdg±4dgt(50/60Hz) ±3%rdg±5dgt(40 - 400Hz)
Conductor size	φ28mm max.
Frequency response	40 - 400Hz
Effect of external stray magnetic field φ15mm 100A	20mA AC max.
Applicable Standards	IEC 61010-1 CAT III 300V IEC 61010-2-032
Power source	R03(AAA) (1.5V) × 2 *Continuous measuring time : approx. 150 hours(Auto power save : approx. 10 minutes)
Dimensions	169(L) × 75(W) × 40(D)mm
Weight	220g approx.
Accessories	9097(Carrying case) R03 × 2 Instruction manual



MODEL 2300R

KEW FORK CURRENT TESTER

True RMS **Ø10** MAX 100A DC AC A NCV DATA HOLD
 AUTO POWER OFF

- True RMS reading is an essential feature for accurate measurement.
- "Non Contact" voltage function indicates the presence of AC voltage by warning the user with an audible signal.
- Set the DC current range to zero in one touch with the Zero Adjust function.
- Auto Power Off.

	2300R
Current measurement	AC A 0 - 100.0A ±2.0%rdg±5dgt [50/60Hz] DC A 0 - ±100.0A ±2.0%rdg±5dgt
Crest factor	2.5
Non contact voltage	Detect AC voltage without contacting with socket wire During voltage detection, "Hi" flashes and a buzzer sounds
Maximum digit	1,049
Conductor size	Max φ10mm
Applicable Standards	IEC 61010-1 CAT III 300V Pollution degree 2
Power source	R03 (AAA) × 2 (Auto power off : approx. 10 minutes) *Continuous measuring time : AC A approx. 46 hours DC A approx. 52 hours
Dimensions	161.3(L) × 40.2(W) × 30.3(D)mm
Weight	110g (including batteries)
Accessories	9113(Carrying case) R03 (AAA) × 2 Instruction manual



KEW FORK 2300R can be used in crowded connection boxes, where cables are very short, and space is too limited to clamp cables using with a traditional clamp meter.



CLAMP SENSOR/CLAMP ADAPTOR

KEW 8115

CLAMP SENSOR



AC DC
 Ø12 MAX 130A MAX 180A DC AC A AUTO POWER OFF



- Permits extension of the AC and DC current ranges of almost any Digital Multimeters (DMMs) without breaking the circuit under test.
- Using KEW 8115 with KEW 1051/1052 (DMM) the display can be set for direct reading in A.

	8115	
Measuring range	AC 0.1 - 130Arms	DC 0 - ±180A
Output voltage	AC 10mV/A	DC 10mV/A
Accuracy	±1.2%rdg±0.4mV (50/60Hz) ±2.5%rdg±0.4mV (40Hz - 1kHz)	±1.2%rdg±0.4mV (*)
Low battery warning	2.2V±0.2V or less - Red LED flash (1.9V±0.2V - Automatically power off)	
Conductor size	φ12mm max.	
Operating temperature & humidity range	-10 to 55°C, relative humidity 85% or less (no condensation)	
Output impedance	Approx. 10Ω or less	
Applicable Standards	IEC 61010-1 CAT III 300V Pollution degree 2, IEC 61010-2-032, IEC 61326-1	
Power source	DC3V (size AAA alkaline battery LR03×2pcs) Continuous use: approx. 40 hours(Auto power off: approx. 20 minutes)	
Cord length	Approx. 1,200mm	
Output connector	φ4mm banana plug	
Dimensions	127(L)×42(W)×22(D) mm	
Weight	Approx. 140g	
Accessories	Soft case, LR03×2, Instruction manual	

*This accuracy is defined after the completion of the KEW 8115 zero-adjustment whilst connected to a DMM.

MODEL 8112/8112BNC

CLAMP ADAPTOR



Ø8 MAX 120A AC A



(8112 Only) photo : 8112

Model 8112 clamp adaptor is designed to be an AC current/voltage conversion probe capable of measuring AC current from 0.1mA to 120A in conjunction with digital multimeters.

Model 8112BNC is an AC clamp adaptor designed for use with oscilloscopes. Output cord has a BNC connector which enables direct observation of current waveform on oscilloscope. Specifications are same as those for Model 8112.

		8112/8112BNC		
Range	Measuring ranges	Output voltage	Accuracy	Frequency response
200mA	AC 0 - 500mA	AC1V/A	±1.5%rdg±0.2mA	50Hz - 1kHz
	AC 0 - 1000mA	(1000mA→1V)	±3%rdg±0.4mA	40Hz - 10kHz
2A	AC 0 - 20A	AC100mV/A	±1%rdg±1mA	40Hz - 1kHz
		(20A→2V)	±1.5%rdg±2mA	1k - 10kHz
20A	AC 0 - 20A	AC10mV/A	±1%rdg±0.01A	40Hz - 1kHz
	AC 20 - 60A		±2.5%rdg	50Hz - 10kHz
	AC 60 - 120A		±2.5%rdg	100Hz - 10kHz
Conductor size	φ8mm max.			
Frequency characteristics	30Hz - 100kHz(-3dB)			
Applicable Standard	IEC 61010-1 CAT II 100V Pollution degree 2(8112 Only).			
Dimensions	153(L) × 18(W) × 23(D)mm			
Weight	100g approx.			
Accessories	9057(Carrying case) Instruction manual			

KEW 8161 NEW

CLAMP SENSOR



Ø24 MAX 100A AC A



- KEW 8161 clamp sensor is designed to be an AC current / voltage conversion probe capable of measuring AC current up to 100A in conjunction with digital multimeters.

	8161
Measuring range	AC0 - 100A
Output voltage	AC 1000mV/AC 100A(10mV/A)
Accuracy	±2.0%rdg±3.0mV (45 - 65Hz) ±2.5%rdg±3.0mV (65 - 1kHz)
Conductor size	φ24mm max.
Operating temperature & humidity range	-10 - 50°C, relative humidity: 85% or less(no condensation)
Output impedance	22Ω or less
Applicable Standards	IEC 61010-1, IEC 61010-2-032, CAT III (300Vrms) Pollution degree 2 IEC 61326-1,2-2, EN50581
Withstand voltage	AC3470Vrms (50/60Hz)for 5 sec.
Insulation resistance	50MΩ or greater at 1000V
Output connector	22Ω or less
Dimensions	97(L) × 59(W) × 26(D)mm
Cable length	Approx. 1.2m
Weight	270g approx.
Accessories	Instruction manual







INSULATION TESTERS





INSULATION TESTERS









INSULATION TESTERS

Selection Guide of Insulation Testers

	Analogue Insulation Testers			Analogue Insulation/Continuity Testers		
	3165	3166	3161A	3431	3131A	3132A
Appearance	 photo : 3165					
Test voltage	1 range		2 ranges	3 ranges		
Rated voltage (Max. measurement value)	500V(1000M Ω)	1000V(2000M Ω)	15V(20M Ω) 500V(100M Ω)	250V(200M Ω) 500V(200M Ω) 1000V(2000M Ω)	250V(100M Ω) 500V(200M Ω) 1000V(400M Ω)	250V(100M Ω) 500V(200M Ω) 1000V(400M Ω)
Continuity Ω	-	-	-	-	2/20 Ω	3/500 Ω
AC Voltage AC V	600V	600V	600V	600V	-	600V
DC Voltage DC V	-	-	-	600V	-	-
Back light 	-	-	✓	✓	✓	-
Power source	R6 x 4	R6 x 4	R6 x 4	LR6 x 4	R6 x 6	R6 x 6
Dimensions (L)x(W)x(D)mm	90x137x40	90x137x40	90x137x40	97x156x46	167x185x89	106x160x72
Weight(Approx.)	330g	330g	340g	430g	860g	560g

	Digital Insulation/Continuity Testers				
	3005A	3007A	3021	3022	3023
Appearance					photo : 3021
Test voltage	3 ranges		4 ranges		
Rated voltage (Max. measurement value)	250V(20M Ω) 500V(200M Ω) 1000V(2000M Ω)	250V(20M Ω) 500V(200M Ω) 1000V(2000M Ω)	125V(200M Ω) 250V(2000M Ω) 500V(2000M Ω) 1000V(2000M Ω)	50V(200M Ω) 100V(200M Ω) 250V(2000M Ω) 500V(2000M Ω)	100V(200M Ω) 250V(2000M Ω) 500V(2000M Ω) 1000V(2000M Ω)
Continuity Ω	20/200/2000 Ω	20/200/2000 Ω	40/400 Ω	40/400 Ω	40/400 Ω
Continuity buzzer 	✓	✓	✓	✓	✓
AC Voltage AC V	600V	600V	20 - 600V	20 - 600V	20 - 600V
DC Voltage DC V	-	-	-20 - -600V 20 - 600V	-20 - -600V 20 - 600V	-20 - -600V 20 - 600V
Back light 	-	✓	✓	✓	✓
Power source	R6 x 8	R6 x 8	R6 x 6	R6 x 6	R6 x 6
Dimensions (L)x(W)x(D)mm	167x185x89	167x185x89	105x158x70	105x158x70	105x158x70
Weight(Approx.)	970g	990g	600g	600g	600g

	Analogue High Voltage Insulation Testers			Digital High Voltage Insulation Testers		
	3121B/3122B	3123A	3124	3025A/3125A	3127	3128
Appearance	 photo : 3121B			 photo : 3125A		
Test voltage	1 range	2 ranges	Variable	3025A: 4 ranges 3125A: 5 ranges	5 ranges	6 ranges(Variable)
Rated voltage (Max. measurement value)	3121B: 2500V(100G Ω) 3122B: 5000V(200G Ω)	5000V(200G Ω) 10000V(400G Ω)	1000V(100M Ω) 1k - 10kV(100G Ω)	250V(100M Ω) 500V(1000M Ω) 1000V(2G Ω) 2500V(100G Ω) 5000V(1000G Ω)*	250V(9.9G Ω) 500V(99.9G Ω) 1000V(199G Ω) 2500V(999G Ω) 5000V(9.99T Ω)	500V(500G Ω) 1000V(1T Ω) 2500V(2.5T Ω) 5000V(5T Ω) 10000V(35T Ω) 12000V(35T Ω)
AC/DC Voltage DC V AC V	-	-	-	30 - 600V AC/DC	30 - 600V AC/DC	30 - 600V AC/DC
Back light 	-	-	-	✓	✓	✓
Current	-	-	-	-	0.00nA - 5.50mA	5.00nA - 2.40mA
Capacitance	-	-	-	-	5.0nF - 50.0 μ F*	5.0nF - 50.0 μ F*
Power source	LR14 x 8	R6 x 8	Ni-Cd rechargeable battery(1.2V) x 8	LR14 x 8	Rechargeable lead storage battery (12V)	Rechargeable lead storage battery (12V)
Dimensions (L)x(W)x(D)mm	177x226x100	200x140x80	200x140x80	177x226x100	380x430x154 (Instrument and Hard case)	330x410x180 (Instrument and Hard case)
Weight(Approx.)	3121B: 1600g 3122B: 1700g	1000g	1500g	3025A: 1700g 3125A: 1900g	8000g	9000g

*3125A only

*At 5000V range 5.0nF - 25.0 μ F

*At 10000/12000V range 5.0nF - 1.0 μ F

DIGITAL INSULATION/CONTINUITY TESTERS

DIGITAL INSULATION/CONTINUITY TESTERS



MODEL 3005A

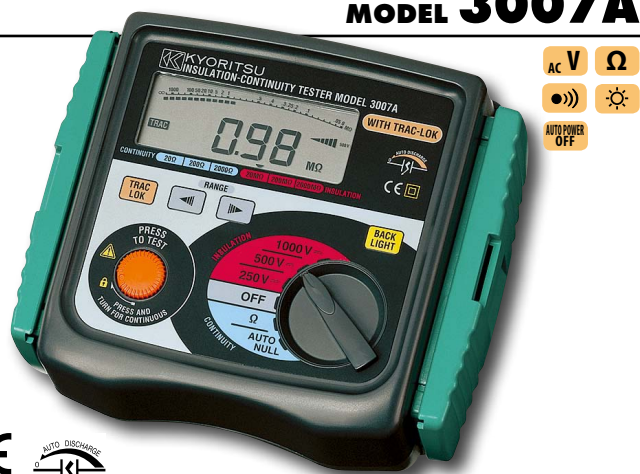

MODEL 3007A

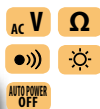

Features (3005A/3007A)

- Bar graph to display insulation resistance.
- Displays the value of external AC voltage along with flashing symbol.
- Auto null function to automatically subtract the test lead resistance before displaying the real continuity resistance value.
- Trac-Lok mode to conserve battery life on insulation and continuity tests (Model 3007A only).
- Live circuit warning beeper.
- Releasing the test button automatically discharges the charges stored in the circuit under test.
- Backlight function to view the test results in dimly lit areas (Model 3007A only).
- 200mA continuity measuring current to IEC 61557.
- Minimum 1mA current on insulation tests to IEC 61557.

	3005A/3007A	
Insulation resistance		
Test voltage	250V/500V/1000V	
Measuring ranges	20MΩ/200MΩ/2000MΩ	
Output voltage on open circuit	Rated test voltage	+20%, -0%
Nominal current	1mA DC min.	
Output short circuit current	1.5 mA DC approx.	
Accuracy	±1.5%rdg±5dgt(20MΩ/200MΩ)	±10%rdg±3dgt(2000MΩ)
Continuity test		
Measuring ranges	20Ω/200Ω/2000Ω	
Output voltage on open circuit	7 - 12V DC	
Measuring current	200mA DC min.	
Accuracy	±1.5%rdg±5dgt(20Ω)	±1.5%rdg±3dgt(200Ω/2000Ω)
AC voltage		
AC voltage range	0 - 600V AC	
Accuracy	±5%rdg±3dgt	
General		
Applicable Standards	IEC 61010-1 CAT III 300V Pollution degree 2 IEC 61557-1/2/4 IEC 60529(IP54) IEC 61326-1(EMC)	
Power source	R6(AA)(1.5V) × 8	
Dimensions	167(L) × 185(W) × 89(D)mm	
Weight	990g approx.(3007A) 970g approx.(3005A)	
Accessories	7122B(Test leads) 9074(Cord case) 8923(Fuse[500mA/600V]) × 2 R6(AA) × 8 9121(Shoulder strap) Instruction manual	

Accessory



MODEL 7122B
Test leads

Selection Guide

	3005A	3007A
250V test voltage	✓	✓
500V test voltage	✓	✓
1000V test voltage	✓	✓
200mA continuity range	✓	✓
Live circuit warning	✓	✓
Illuminated scale		✓
Automatic discharge	✓	✓
Trac-loc for extended battery life		✓

DIGITAL INSULATION/CONTINUITY TESTERS

KEW 3021/3022/3023



- 3 functions in one unit, insulation test with 4 voltage ranges, continuity test, AC voltage measurement.
- 200mA measuring current on continuity testing.
- Comparator function with PASS / FAIL and buzzer.
- 0Ω adjustment at continuity measuring range.
- Memory function up to 99 data.
- Backlight LCD provides easy reading in dark locations.
- Safety lock system prevents an erroneous operation



photo : 3021

	3021				3022				3023			
Insulation resistance												
Test voltage	125V	250V	500V	1000V	50V	100V	250V	500V	100V	250V	500V	1000V
Measuring range (Auto range)	4.000/40.00/200.0MΩ				4.000/40.00/200.0MΩ		4.000/40.00/400.0/2000MΩ		4.000/40.00/200.0MΩ		4.000/40.00/400.0/2000MΩ	
First effective measuring range	0.2 - 20MΩ		0.2 - 40MΩ		0.2 - 200MΩ		0.2 - 1000MΩ		0.2 - 20MΩ		0.2 - 40MΩ	
Mid-scale value	5MΩ		50MΩ		5MΩ		50MΩ		5MΩ		50MΩ	
Accuracy	±2%rdg±6dgt											
Second effective measuring range lower	0.110 - 0.199MΩ											
Second effective measuring range upper	20.01 - 200.0MΩ		40.01 - 2000MΩ		200.1 - 2000MΩ		1001 - 2000MΩ		20.01 - 200.0MΩ		40.01 - 2000MΩ	
Accuracy	±5%rdg±6dgt											
Rated current	DC 1 - 1.2mA											
Output short circuit current	1.5mA max											
Ω/Continuity												
Auto range	40.00/400.0Ω											
Accuracy	±2%rdg±8dgt											
Output voltage on open circuit	5V±20%											
Output short circuit current	DC 220±20mA											
Fuse	Quick acting ceramic fuse 0.5A/600V(φ6.35×32mm)											
AC voltage												
Range	AC 20 - 600V(50/60Hz) DC -20 - -600V/+20 - +600V											
Accuracy	±3%rdg±6dgt											
General												
Applicable Standards	IEC 61010-1 CAT III 600V IEC 61557-1,2,4 IEC 61326-1(EMC) IEC 60529(IP40)											
Dimensions / Weight	105(L) × 158(W) × 70(D)mm / 600g approx.											
Power source	R6×6 or LR6×6											
Accessories	7150A(Test Lead with remote control switch set) 9121(Shoulder strap) R6(AA) × 6 Instruction manual											
Optional	7115(Extension probe) 8016(Hook type prod) 8923(Fuse[0.5A/600V]) 9089(Carrying case)											

Accessory

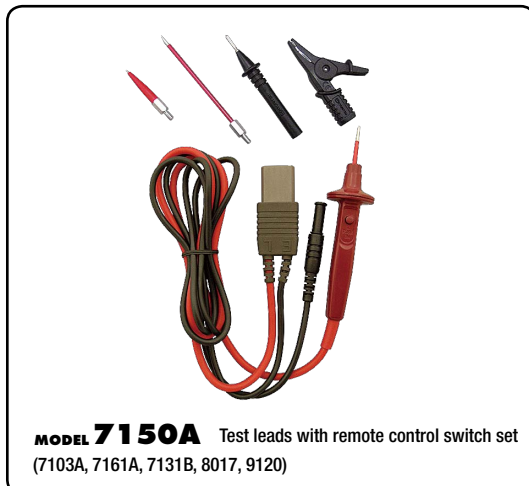

Optional Accessories

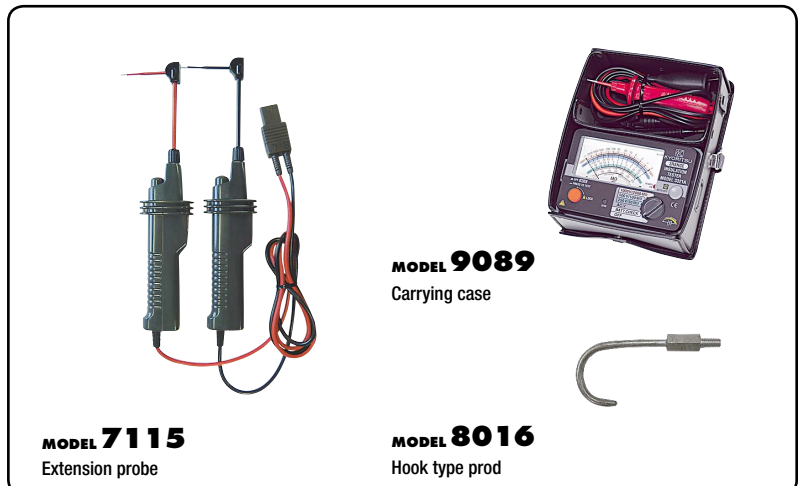

ANALOGUE INSULATION/CONTINUITY TESTERS

MODEL 3131A



- Test insulation up to 100M Ω at 250V, 200M Ω at 500V, 400M Ω at 1000V and continuity up to 20 Ω .
- LIVE circuit warning lamp plus audible warning.
- Automatic discharge of circuit capacitance when TEST button is released.
- Fuse protected (continuity range only).
- Battery check LED.
- Front panel zero adjust.
- Back light function to facilitate working at dimly lit situations.
- PRESS TO TEST button with lock down feature.

3131A	
Insulation resistance	
Test voltage	250V/500V/1000V
Measuring ranges (Mid-scale value)	100M Ω /200M Ω /400M Ω (1M Ω) (2M Ω) (4M Ω)
Output voltage on open circuit	Rated test voltage +20%, -0%
Nominal current	1mA DC min.
Output short circuit current	1.3 mA DC approx.
Accuracy	0.1 - 10M Ω /0.2 - 20M Ω /0.4 - 40M Ω (Accuracy guaranteed ranges) \pm 5% of indicated value
Continuity	
Measuring ranges (Mid-scale value)	2 Ω /20 Ω (1 Ω)(10 Ω)
Output voltage on open circuit	4 - 9V DC
Measuring current	200mA DC min.
Accuracy	\pm 3% of scale length
General	
Applicable Standards	IEC 61010-1 CAT III 300V Pollution degree 2 IEC 61557-1/2/4 IEC 60529(IP54) IEC 61326-1(EMC)
Power source	R6(AA)(1.5V) \times 6
Dimensions	167(L) \times 185(W) \times 89(D)mm
Weight	860g approx.
Accessories	7122B(Test leads) 9074(Cord case) 8923(Fuse[0.5A/600V]) \times 2 R6(AA) \times 6 9121(Shoulder strap) Instruction manual

MODEL 3132A



- Dust and drip proof construction. (designed to IEC 60529 IP54)
- Designed to meet IEC 61010-1 and IEC 61557 safety standard.
- 1mA rated test current at the minimum resistance.
- 200mA measuring current on continuity testing.
- Automatic discharge of circuit capacitance. (Any charge stored in the circuit under test will be automatically discharged after testing.)
- Live circuit warning buzzer and neon lamp.
- Small and lightweight. Shock resistant new case material.
- AC voltmeter with linear, easy-to-read scale.
- Operates on AA, R6 \times 6 dry batteries.

3132A	
Insulation resistance	
Test voltage	250V/500V/1000V
Measuring ranges (Mid-scale value)	100M Ω /200M Ω /400M Ω (1M Ω) (2M Ω) (4M Ω)
Output voltage on open circuit	Rated test voltage +20%, -0%
Nominal current	1mA DC min.
Output short circuit current	1 - 2mA DC
Accuracy	0.1 - 10M Ω /0.2 - 20M Ω /0.4 - 40M Ω (Accuracy guaranteed ranges) \pm 5% of indicated value
Continuity	
Measuring ranges (Mid-scale value)	3 Ω /500 Ω (1.5 Ω /20 Ω)
Output voltage on open circuit	4.1V DC approx.
Measuring current	210mA DC min.
Accuracy	\pm 1.5% of scale length
AC voltage	
AC voltage range	0 - 600V AC
Accuracy	\pm 5% of scale length
General	
Applicable Standards	IEC 61010-1 CAT III 600V Pollution degree 2 IEC 61557-1/2/4 IEC 60529(IP54) IEC 61326-1(EMC)
Power source	R6(AA)(1.5V) \times 6
Dimensions	106(L) \times 160(W) \times 72(D)mm
Weight	560g approx.
Accessories	7122B(Test leads) 9074(Cord case) 8923(Fuse[0.5A/600V]) \times 2 R6(AA) \times 6 9121(Shoulder strap) Instruction manual

Accessory



MODEL 7122B
Test leads

Selection Guide

	3131A	3132A
3 range insulation test voltage	✓	✓
200mA continuity	✓	✓
Live circuit warning	✓	✓
AC voltage range	✓	✓
Illuminated scale	✓	
Automatic discharge	✓	✓
IP54 rate	✓	✓

ANALOGUE INSULATION TESTERS

MODEL 3161A



AC V



- Miniature lightweight insulation tester. It weighs only 340g(battery included), but carries full measurement functions.
- Automatic discharge of circuit capacitance.
- Test leads with remote control switch .
- New robust housing case.
- Back light function.

3161A	
Insulation resistance	
Test Voltage	15V/500V
Max. effective scale value	20M Ω /100M Ω
Mid-scale value	0.05M Ω /2M Ω
First effective measuring ranges	0.005 - 2M Ω /0.1 - 50M Ω
Accuracy	\pm 5% of indicated value
Second effective measuring ranges	Measuring ranges other than above, 0 and ∞
Accuracy	\pm 10% of indicated value
AC voltage	
AC voltage range	600V
Accuracy	\pm 3% of full scale value
Applicable Standards	IEC 61010-1 CAT III 300V, CAT II 600V
Power source	R6(AA)(1.5V) \times 4
Dimensions	90(L) \times 137(W) \times 40(D)mm
Weight	340g approx.
Accessories	7149A(Test leads with remote control switch set) 9123(Shoulder strap) R6(AA) \times 4, Instruction manual
Optional	7116(Extension probe), 8016(Hook type prod)

MODEL 3165/3166



AC V

- 500V/1000M Ω (Model 3165)
- 1000V/2000M Ω (Model 3166)
- Expanded megohm scale for easy reading.
- New robust housing case to prevent damage.
- AC voltmeter scale for easy reading.

photo : 3165

	3165	3166
Insulation resistance		
Test voltage	500V	1000V
Max. effective scale value	1000M Ω	2000M Ω
Mid-scale value	20M Ω	50M Ω
First effective measuring range	1 - 500M Ω	2 - 1000M Ω
Accuracy	\pm 5% rdg	
Second effective measuring range	0.5/1000M Ω	1/2000M Ω
Accuracy	\pm 10% rdg	
AC voltage		
AC voltage range	600V	
Accuracy	\pm 3% of full scale value	
Power source	R6(AA)(1.5V) \times 4	
Dimensions	90(L) \times 137(W) \times 40(D)mm	
Weight	330g approx.	
Accessories	7025(Test leads), 9074(Cord case), 9123(Shoulder strap) R6(AA) \times 4, Instruction manual	

KEW 3431



DC AC V

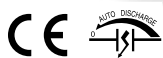

- Compact and lightweight design.
- Scale light and LED spot light to facilitate working at dimly illuminated location or at nighttime work.
- Built-in illuminance sensor automatically turns on/off the lights.
- Test probe with remote control switch is supplied as standard accessory.
- Live circuit warning with blinking LED and buzzer.

3431		
Insulation resistance		
Test Voltage	250V	500V
Max. effective scale value	200M Ω	1000V
Mid-scale value	5M Ω	2000M Ω
First effective measuring ranges	0.1M Ω - 100M Ω	1M Ω - 1000M Ω
Accuracy	\pm 5% of indicated value	
Second effective measuring ranges	Measuring ranges other than above, 0 and ∞	
Accuracy	\pm 10% of indicated value	
AC voltage		
AC voltage range	AC 600V (45 - 65Hz)/DC 600V	
Accuracy	\pm 5% of indicated value	
Applicable Standards	CAT III 600V	
Power source	LR6/R6(AA)(1.5V) \times 4	
Dimensions	97(L) \times 156(W) \times 46(D)mm	
Weight	430g approx.	
Accessories	7260(Test lead with remote control switch set), 7261(Test lead with alligator clip), 9173(Carrying case), 8017A(Extension prod long), 9121(Shoulder strap), LR6(AA) \times 4, Instruction manual	
Optional	7243(L-shaped probe), 8016(Hook type prod)	

HIGH VOLTAGE INSULATION TESTERS

2500V **NEW** / 5000V **NEW**
KEW 3121B / **3122B**



photo : 3121B



photo : 3122B

- Easy and simple operation.
- Automatic ranges, indicated by different LED's.
- Newly-designed alligator clip.
- It comes with a tough hard case.
- Safety standard IEC 61010-1 CAT IV 300V

CE

	3121B	3122B
Test voltage	2500V	5000V
Measuring ranges (automatic change)	2GΩ/100GΩ (auto ranging)	5GΩ/200GΩ (auto ranging)
First effective measuring ranges	0.1 - 50GΩ	0.2 - 100GΩ
Accuracy	±5% rdg	
Other ranges accuracy	±10% rdg or 0.5% of scale length	
Short circuit current	0.08mA	
Applicable Standards	IEC 61010-1, 61010-2-030 CAT IV 300V, CAT III 600V Pollution degree 2, IEC 61326-1, 61326-2-2(EMC), IEC 60529(IP40)	
Power source	DC12V:LR14 × 8	
Dimensions	177(L) x 226(W) x 100(D) mm	
Weight	1.6kg approx.	1.7kg approx.
Accessories	7165A(Line probe)(3m), 7264(Earth cord)(3m), 7265(Guard cord)(3m), 8019(Hook type prod), 9182(Carrying case[Hard]), LR14 x 8, Instruction manual	7165A(Line probe)(3m), 7264(Earth cord)(3m), 7265(Guard cord)(3m), 8019(Hook type prod), 9183(Carrying case[Hard]), LR14 x 8, Instruction manual
Optional	7168A(Line probe with alligator clip)(3m), 7253(Longer line probe with alligator clip)(15m), 8324(Adaptor for recorder)	

Optional Accessories

MODEL 7168A
Line probe with alligator clip : 3000mm

MODEL 7253
Longer line probe with alligator clip:15m

MODEL 8324
Adaptor for recorder (Output 10mV/1μA)
Cable length : 200mm
Alligator clip side : 1100mm

HIGH VOLTAGE INSULATION TESTERS

2500V 5000V
KEW 3025A NEW / 3125A NEW



photo : 3125A

DC AC V AUTO POWER OFF

- Large digital display with Bar Graph indication and back light.
- Polarization Index measurement(PI)
- Dielectric Absorption Ratio(DAR).
- Indication of Output voltage and Discharge voltage.
- Safety standard IEC 61010-1 CAT IV 300V / CAT III 600V



photo : 3025A



3025A/3125A						
Range	Insulation resistance					Voltage measurement
Test voltage	250V	500V	1000V	2500V	5000V*1	
Measuring range	0.0 - 100.0MΩ	0.0 - 99.9MΩ 80 - 1000MΩ	0.0 - 99.9MΩ 80 - 999MΩ 0.80 - 2.00GΩ	0.0 - 99.9MΩ 80 - 999MΩ 0.80 - 9.99GΩ 8.0 - 100.0GΩ	0.0 - 99.9MΩ 80 - 999MΩ 0.80 - 9.99GΩ 8.0 - 99.9GΩ 80 - 1000GΩ	30 - 600V AC/DC (50/60Hz)
Accuracy	±5%rdg±3dgt	±5%rdg±3dgt	±5%rdg±3dgt	±5%rdg±3dgt	±5%rdg±3dgt ±20%(100GΩ or more)	±2%rdg±3dgt
Short circuit current	1.5mA					—
Rated test current	0.7mA - 0.9mA at 0.25MΩ load	0.8mA - 1mA at 0.5MΩ load	1mA - 1.2mA at 1MΩ load	1mA - 1.2mA at 2.5MΩ load	1mA - 1.2mA at 5MΩ load	—
Open circuit voltage	250V +10%, -10%	500V +20%, -10%	1000V +20%, -0%	2500V +20%, -0%	5000V +20%, -0%	—
Applicable Standard	IEC 61010-1, 61010-2-030 CAT IV 300V, CAT III 600V Pollution degree 2, IEC 61326-1, 2-2					
Power source	DC12V:LR14 x 8					
Dimensions	177(L) × 226(W) × 100(D) mm					
Weight	1.7kg approx. : 3025A 1.9kg approx. : 3125A					
Accessories	7165A(Line probe)(3m), 7264(Earth cord)(3m), 7265(Guard cord)(3m), 8019(Hook type prod), 9180(Carrying case for 3025A) 9181(Carrying case for 3125A), LR14(Alkaline battery size C) × 8, Instruction manual					
Optional	7168A(Line probe with alligator clip)(3m), 7253(Longer line probe with alligator clip)(15m), 8302(Adaptor for recorder)					

*1) KEW3125A only

Accessories



MODEL 7165A
Line probe 3,000mm



MODEL 7264
Earth cord 3,000mm



MODEL 7265
Guard cord 3,000mm



MODEL 8019
Hook type prod



MODEL 9180/9181
Carrying case [Hard]
9180(3025A)/9181(3125A)

HIGH VOLTAGE INSULATION TESTERS

HIGH VOLTAGE INSULATION TESTERS

5000V

KEW **3127**

CAT IV 600V DC AC V USB AUTO POWER OFF Bluetooth

- Insulation Resistance up to 10TΩ
- Short-Circuit Current up to 5mA
- Wide Test Voltage from 250V to 5000V
- Diagnostic Insulation Tests: IR, PI, DAR, DD, SV, RAMP.
- Wireless communication by Bluetooth for transferring and showing real-time data to PC and Android device.
- Memory and Logging functions.
- Filter function reduces noise interference.
- Robust design for field use with IP65 (lid closed).
- Powered by rechargeable battery.

Function

PI **DAR** **DD** **SV** **RAMP**



3127

Insulation resistance

Test voltage	250V *1	500V	1000V	2500V	5000V
Max measurement value	9.99GΩ	99.9GΩ	199GΩ	999GΩ	9.99TΩ
Accuracy	0.0 - 99.9MΩ ±5%rdg±3dgt	0.0 - 999MΩ ±5%rdg±3dgt	0.0 - 1.99GΩ ±5%rdg±3dgt	0.0 - 99.9GΩ ±5%rdg±3dgt	0.0 - 99.9GΩ ±5%rdg±3dgt
	0.1G - 9.99GΩ ±20%rdg	1G - 99.9GΩ ±20%rdg	2G - 199GΩ ±20%rdg	100G - 999GΩ ±20%rdg	0.1T - 9.99TΩ ±20%rdg
Short circuit current	Max 5.0mA				
Output voltage	Accuracy	-10 - +10%	-10 - +20%	0 - +20%	-20% - 0% (5%step)
	Variable	-			-20% - 0% (5%step)
Monitor	±10%rdg±20V				
Measuring range	Voltage measurement		Current measurement		Capacitance measurement
	AC:30 - 600V (50/60Hz) DC:±30 - ±600V		0.00nA - 5.50mA		5.0nF - 50.0μF *2
Accuracy	±2%rdg±3dgt		±10%rdg*3		±5%rdg±5dgt
Power source	Rechargeable Battery (Lead-acid Battery) 12V*4 Charging power : DC 15VA MAX				
Communication Interface	Bluetooth:Ver2.1 + EDR Class2 , USB:Ver1.1				
Applicable Standards	IEC 61010-1, 61010-2-030 CAT IV 600V Pollution degree2, IEC 61326-1, 2-2				
Dimension	208(L) x 225(W) x 130(D) mm (Hard case 380(L) x 430(W) x 154(D) mm)				
Weight	3127:4kg Approx. (including battery), Total:8kg Approx. (including Accessories)				
Accessories	7165A(Line probe), 7224A(Earth cord), 7225A(Guard cord), 8019(Hook type prod), 8327EU(Power adaptor 15V/1A), 9171(Carrying case[Hard]), Instruction manual				
Optional	7168A(Line probe with alligator clip:3m), 7253(Longer line probe with alligator clip:15m), 8258(USB communication set), 8302(Adaptor for recorder 1mV/1μA)				

*1) IR mode only *2) At 5000V range 5.0nF-25.0μF *3) Determined by resistance and Voltage values (over 10MΩ) *4) No measurements are possible while charging ※ Bluetooth is a registered trademark of the Bluetooth SIG, Inc.

Data Communication Function

- Transferring and showing real-time data to PC and Android tablet
- Recorded data can be transferred (PC only)
- Analyzing of the saved data (PC only)



※Free Android software is available on download site

Optional Accessories



System requirements

OS: Windows®Vista/7/8/10
Display: XGA (Resolution 1024 x 768 dots) or more
Hard-disk: Space required 100Mbyte or more
Others: With CD-ROM drive and USB port
* Windows® is a registered trademark of Microsoft in the United States.

Diagnostic Insulation Tests

PI Polarization Index

$$PI = \frac{\text{Insulation resistance value 10 min. after start}}{\text{Insulation resistance value 1 min. after start}}$$

PI Criteria	4.0 or more Best	4.0-2.0 Good	2.0-1.0 Warning	1.0 or less Bad
-------------	------------------	--------------	-----------------	-----------------

DAR Dielectric Absorption Ratio

$$DAR = \frac{\text{Insulation resistance value 1 min. after start}}{\text{Insulation resistance value *15 sec. after start}}$$

DAR Criteria	1.4 or more Best	1.25-1.0 Good	1.0 or less Bad
--------------	------------------	---------------	-----------------

*User-Selectable 15sec. or 30sec. interval

DD Dielectric Discharge

$$DD = \text{Current value 1 min. after completing (mA)}$$

$$\text{Voltage value when a measurement complete (V) x Capacitance (F)}$$

DD Criteria	2.0 or less Good	2.0-4.0 Warning	4.0-7.0 Poor	7.0 or more Very poor
-------------	------------------	-----------------	--------------	-----------------------

HIGH VOLTAGE INSULATION TESTERS

12000V

KEW 3128



CAT IV 600V DC AC V AUTO POWER OFF USB External Power Supply

- Test Voltage 12kV (max), Resistance 35TΩ (max).
- Short-Circuit Current 5mA (max).
- Graphic representation of the insulation resistance and leakage current versus time on large display with bar graph and backlight.
- Print Screen Function enables to record up to 32 display screens.
- Internal Memory can store about 43,000 data (max).
- Can be operated from internal rechargeable battery or from AC line.
- Robust design for field use with IP64 rating (with lid closed).

Function

PI DAR DD SV

		3128					
Insulation resistance	Test voltage	500V	1000V	2500V	5000V	10000V	12000V
	Max measurement value	500GΩ	1TΩ	2.5TΩ	5TΩ	35TΩ	
	Accuracy	400kΩ - 50GΩ ±5%rdg±3dgt	800kΩ - 100GΩ ±5%rdg±3dgt	2MΩ - 250GΩ ±5%rdg±3dgt	4MΩ - 500GΩ ±5%rdg±3dgt	8MΩ - 1TΩ ±5%rdg±3dgt	
		50G - 500GΩ ±20%rdg	100G - 1TΩ ±20%rdg	250G - 2.5TΩ ±20%rdg	500G - 5TΩ ±20%rdg	1T - 10TΩ ±20%rdg 10T - 35TΩ Values are displayed, but accuracy isn't guaranteed	
	Short circuit current	Max 5.0mA					
Load resistor to output rated voltage	0.5MΩ or more	1MΩ or more	2.5MΩ or more	5MΩ or more	20MΩ or more	24MΩ or more	
Output voltage	Rated voltage	500V	1000V	2500V	5000V	10000V	12000V
	Monitor accuracy	±10%±20V					
	Output accuracy	0 - +20%	0 - +10%	0 - +10%	0 - +10%	-5 - +5%	-5 - +5%
Voltage measurement	Selectable range	50 - 600V (in steps of 5V)	610 - 1200V (in steps of 10V)	1225 - 3000V (in steps of 25V)	3050 - 6000V (in steps of 50V)	6100 - 10000V (in steps of 100V)	10100 - 12000V (in steps of 100V)
	Measuring range	DCV : ±30 - ±600V, ACV : 30 - 600V(50/60Hz)					
Current measurement	Accuracy	±2%rdg±3dgt					
	Measuring range	5.0nA - 2.40mA(Depending on the insulation resistance)					
Capacitance measurement	Accuracy	±5%rdg±5dgt					
	Measuring range	5.0nF - 50.0μF					5.0nF - 1.0μF (Display range : 5.0nF - 50.0μF)
General	Applicable Standards	IEC 61010-1 CAT IV 600V Pollution degree 2, IEC 61326, IEC 60529(IP64): with the lid closed.					
	Power source	Rechargeable Lead storage battery (12V *Charging time : approx. 8 hours) / AC Power supply (100V - 240V, 50/60Hz) ※Continuous measuring time: approx. 4 hours a load of 100MΩ at the Insulation resistance 12000V Range.					
	Dimensions	330(L) × 410(W) × 180(D)mm *Instrument and Hard case					
	Weight	9kg approx. (including battery) *Instrument and Hard case					
	Accessories	7170(Power cord), 7224A(Earth cord), 7225A(Guard cord), 7226A(Line probe), 7227A(Line probe with alligator clip), 8029(Extension prod), 8255(CAT IV Standard prod), 8212-USB-W(USB adaptor with KEW Windows(Software)), Instruction manual					
	Optional	7254(Longer line plode with alligator clip)(15m)					

SV SV Measurement (Step Voltage)

During the test, the applied voltage incrementally steps by a certain voltage taking successive 5-time measurement. Degradation of insulation may be doubted when insulation resistances become lower at higher applied voltages.

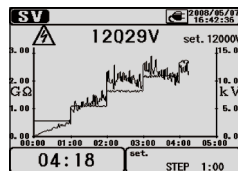

RAMP RAMP TEST

Voltage used in Step voltage test is raised in steps but that used in Ramp measurement is gradually raised.

The KEW 3127 Ramp test generates a rising voltage ramp up to the selected voltage.

[Breakdown Mode]

KEW 3127 automatically stops the test if the insulation breaks down in order to prevent damage to the object being tested.

[Burn Mode]

KEW 3127 allows the insulation test voltage to continue even after the insulation breaks down. This enables you to locate a fault, such as pinholes in windings, by seeing a spark or a wisp of smoke.

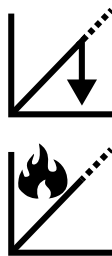

Large Graphical Display

Graphic representation of the insulation resistance and leakage current versus time on large display with bar graph and backlight.

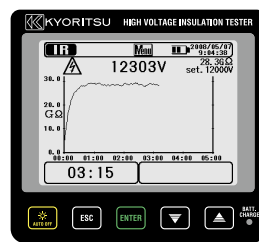

"KEW Windows" Software for report

The stored data can be transferred to PC via MODEL8212-USB.



System requirements

- OS: Windows VISTA/7/8/10
 - Display: XGA (Resolution 1024 x 768 dots) or more
 - Hard-disk: Space required 100Mbyte or more
 - Others: With CD-ROM drive and USB port
NET Framework(2.0 or more)
- * Windows® is a registered trademark of Microsoft in the United States.

Optional Accessory

MODEL 7254

Longer line probe with alligator clip : 15m



HIGH VOLTAGE INSULATION TESTERS

10000V

KEW 3123A



	3123A	
Test voltage	5000V	10000V
Measuring ranges (automatic change)	5GΩ/200GΩ (autoranging)	10GΩ/400GΩ (autoranging)
First effective measuring ranges	0.2 - 100GΩ	0.4 - 200GΩ
Accuracy	±5% rdg	
Other ranges accuracy	±10% rdg or 0.5% of scale length	
Power source	R6(AA)(1.5V) × 8	
Dimensions	200(L) × 140(W) × 80(D)mm	
Weight	1kg approx.	
Accessories	7165A(Line probe)(3m), 7224A(Earth cord)(1.5m), 7225A(Guard cord)(1.5m), 8019(Hook type prod), 9158(Carrying case [Hard]), R6(AA) × 8, Instruction manual	
Optional	7253(Longer line probe with alligator clip)(15m), 7168A(Line probe with alligator clip)(3m), 8324(Adaptor for recorder)	

- Rugged design with a hard carrying case for field use.
- Detachable High Voltage Line probe.
- Automatic ranges, high and low scales, indicated by different LEDs.
- Drip proof.
- Auto-discharge function.

Accessories



MODEL 7165A
line probe 3,000mm



MODEL 7224A
Earth cord 1,500mm



MODEL 7225A
Guard cord 1,500mm



MODEL 8019
Hook type prod



MODEL 9158
Carrying case [Hard]

Optional Accessories



MODEL 7168A
Line probe with alligator clip:3m



MODEL 7253
Longer line probe with alligator clip:15m



MODEL 8324
Adaptor for recorder (Output 10mV/1μA)
Cable length:
200mm connector side
1100mm alligator clip side

Use of Guard Terminal

Illustrated in this Fig. is an example of the insulation resistance measurement of an electric wire. If the line probe is simply connected to the wire conductor and the earth lead to the immersion liquid container as shown, a measurement error will be introduced as this results in the measurement of the combined resistance of insulation resistance and the surface leakage resistance at the cut end of the electric wire. In order to remove this surface leakage current, wind a guard wire around the cut end of the conductor and connect it to the guard terminal of the instrument using the guard lead. Then, the surface leakage current will bypass the indicating meter of the insulation resistance tester.

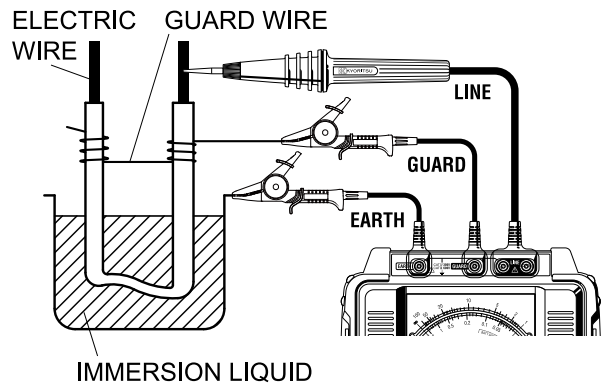

HIGH VOLTAGE INSULATION TESTERS

10000V

MODEL 3124

External Power Supply



	3124	
Test voltage	1k - 10kV variable	1000V
Measuring ranges (automatic change)	1.6GΩ/100GΩ (autorange)	100MΩ
First effective measuring ranges	0.05 - 50GΩ	1 - 100MΩ
Accuracy	±10% rdg	
Other ranges accuracy	±1% of scale length	
Output voltage and set voltage indicate	DC 0 - 10kV ±2%rdg±2dgt	
Power source	Ni-Cd rechargeable battery(1.2V) × 8	
Dimensions	200(L) × 140(W) × 80(D)mm	
Weight	1.5kg approx.	
Accessories	7082(Lead for recorder), 7083(Lead for battery charging), 7084(Earth and guard leads), 9176(Carrying case[Hard]), 8075(Battery charger[120V]) or 8080A(Battery charger[220V]), Ni-Cd rechargeable battery × 8, Instruction manual	

- Permits a wide range of insulation testing up to 100GΩ at variable test voltage from 1kV to 10kV.
- DC voltage output for recorders.
- Output voltage is shown on the digital display.
- After tests, automatically discharges the charges stored in the circuit under test.
- Operated by rechargeable Nickel-Cadmium batteries.

Accessories

MODEL 7082
Lead for recorder : 1,100mm



MODEL 7083
Lead for Battery charging : 5,200mm



MODEL 7084
Earth and guard leads : 5,000mm



Battery charger

MODEL 8075
120V



OR

MODEL 8080A
220V



MODEL 9176
Carrying case[Hard]



Instrument Layout

- | | |
|--|--------------------------------|
| ① Line Probe | ⑬ Output Terminal for Recorder |
| ② Guard Terminal | ⑭ Pressto Test Buton |
| ③ Earth Terminal | ⑮ Function Switch |
| ④ Battery Alarm | ⑯ Output Voltage Set Knob |
| ⑤ Battery Charging Indicator | |
| ⑥ High Scale for 100GΩ Range | |
| ⑦ Low Scale for 100GΩ Range | |
| ⑧ High Scale Indicator for 100GΩ Range | |
| ⑨ Low scale Indicator for 100GΩ Range | |
| ⑩ Output Voltage and Set Voltage Indicator | |
| ⑪ Meter Movement Zero Adjust | |
| ⑫ Terminal for Battery Charging | |

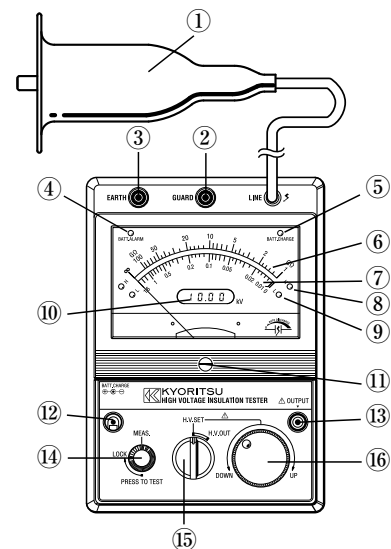

EARTH TESTERS

EARTH TESTERS



EARTH TESTERS

Measurement of the earth electrode resistance (3-Pole method)

[MODEL 4102A/KEW 4105A/KEW 4105DL]

The international standard IEC 60364-6 provides information regarding the measurement of the resistance of an earth electrode for TT, TN and IT systems. This measurement shall be made by the Volt-Amperometric method using two auxiliary earth electrodes. The instrument that covers this requirement is the Earth Tester.

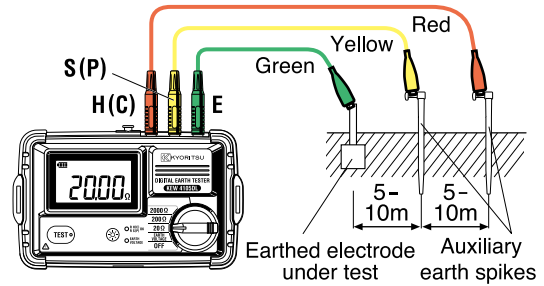

Precise Measurement

Measurement of the simplified earth resistance (2-Pole method)

[KEW 4300/MODEL 4102A/KEW 4105A/KEW 4105DL]

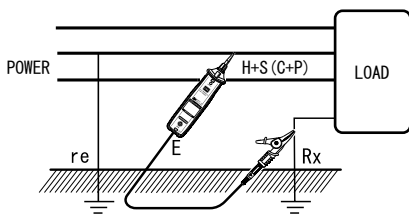

Measuring the earth resistance of load

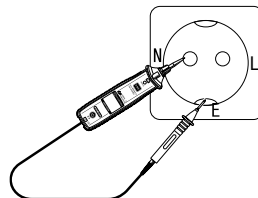

Measuring the earth resistance of wall socket

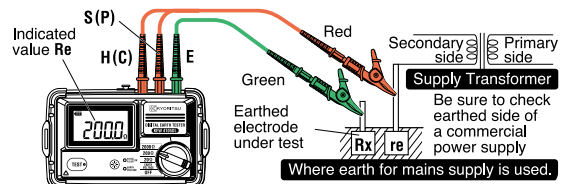

Simplified Measurement

Supply Transformer
Be sure to check earthed side of a commercial power supply
Where earth for mains supply is used.

Measurement of the earth resistance with Earth Clamp (Why earth measurements can be found by only clamping it?)

[MODEL 4200/KEW 4202]

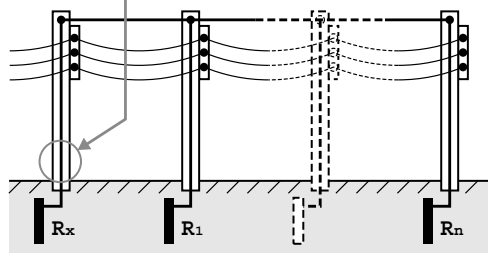
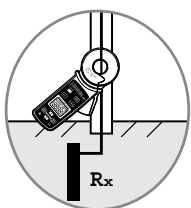

R_x is defined as earth resistance under test, and R₁, R₂...R_n are defined as earth resistance of other measuring objects.

These earth resistances, R₁, R₂, ... R_n can be considered that they are connected in parallel. And They can be regarded as a combined resistance R_s. The R_s can be regarded small enough against R_x since a combined resistance consists of several resistances.

Following is an equivalent circuit diagram of this circuit.

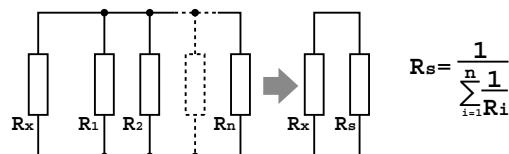

Voltage V is applied to the object (Resistance R_x) measured from the voltage injection transformer CT1, and the current I corresponding to the earth resistance is flowed.

$$\frac{V}{I} = R = R_x + R_s$$

$$R_x \gg R_s = \frac{1}{\sum_{i=1}^n \frac{1}{R_i}}$$

$$\frac{V}{I} = R_x$$

The current I is detected with detection transformer CT2, and object (Resistance R_x) measured can be put out by the calculation. (refer to the right diagram)

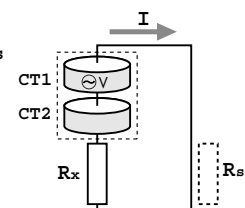

EARTH TESTERS

KEW 4105DL-H NEW



WP
AUTO POWER OFF

4105DL-H			
Earth resistance measurement	20Ω	200Ω	2000Ω
Measuring range	0.00 - 2000 Ω		
	0.00 - 20.99 Ω	0.0 - 209.9 Ω	0.0 - 2099 Ω
Accuracy* ¹	±1.5%rdg±0.08 Ω* ² ±1.5%rdg±4dgt		
Earth voltage measurement			
Measuring range	0 - 300 V AC (45 - 65Hz)	±0 - ±300 V DC	
Display range	0.0 - 314.9 V	0.0 - ±314.9 V	
Accuracy	±1%rdg±4dgt		
Overload protection	Earth resistance:360V AC(10 Seconds) Earth Voltage:360V AC(10 Seconds)		
Applicable Standards	IEC 61010-1, CAT IV 100 V /CAT III 150 V /CAT II 300 V Pollution degree 3 IEC 61010-2-030, IEC 61010-031, IEC 61557-1, -5 IEC 60529 IP67, IEC 61326-1, -2-2, EN50581(RoHS)		
Power source	LR6(AA)(1.5V) × 6		
Dimensions	121(L) × 188(W) × 59(H) mm (including case lid)		
Weight	Approx. 690g (including batteries and case lid)		
Accessories	7266(Earth resistance test leads [red-20m, yellow-10m, green-5m/1set]), 7127B(Simplified measurement probe), 8041(Auxiliary earth spikes[2 spikes/1set]), 9121(shoulder strap), 9191(Hard case), LR6(AA) × 6, Instruction manual		
Optional	7272(Precision measurement Cord set), 8259(Adapter for measurement terminal)		

*1 For precision measurement, auxiliary earth resistance should be 100 Ω ±5% or less.
 *2 At simplified measurement add ±0.10 Ω to the specified accuracy.

CE

- 3pole and 2pole Earth Resistance measurement (0.01Ω-2000Ω)
- Waterproof design (IP67)
- Rotary Switch makes the user interface very intuitive
- Large LCD Display with Backlight
- Led to monitor correct / non correct auxiliary earth spike resistance
- Earth Voltage Measurement (AC/DC 0-300V)
- CAT IV 100V

Water and dust proof: after use you can wash it to remove the mud and dust!



Adapter to enable use of other test leads



Innovative Cable reel with wire guide system to facilitate rewinding



Accessories



MODEL 7266
Earth resistance test leads



MODEL 7127B
Simplified measurement probe



MODEL 8041
Auxiliary earth spikes [2spikes/1set]



MODEL 9191
Carrying case [Hard]



Optional Accessories



MODEL 7272
Precision measurement cord set (7267, 7268, 7271, 8041, 9192)

< MODEL7272 precision measurement cord set >



MODEL 7267
Cable reel for Earth resistance tester (red)



MODEL 7268
Cable reel for Earth resistance tester (yellow)



MODEL 7271
Earth resistance test leads



MODEL 8041
Auxiliary earth spikes [2spikes/1set]



MODEL 9192
carrying case



MODEL 8259
Adapter for measurement terminal

EARTH TESTERS

MODEL 4102A



CE

4102A/4102A-H			
Earth resistance measurement	x 1Ω Range	x 10Ω	x 100Ω
Measuring range	0 - 12 Ω	0 - 120 Ω	0 - 1200 Ω
Accuracy	±3% of full scale		
Earth voltage measurement			
Measuring range	0 - 30 V AC (50,60Hz)		
Accuracy	±3% of full scale		
Overload protection	Earth resistance : 276V AC/DC (10 seconds) Earth voltage : 276V AC/DC (10 seconds)		
Applicable Standards	IEC 61010-1 CAT III 300 V Pollution degree 2 IEC 61010-2-030, IEC 61557-1, -5, IEC 60529 IP54, EN50581(RoHS)		
Power source	R6(AA)(1.5V) × 6		
Dimensions	105(L) × 158(W) × 70(H) mm (including case lid)		
Weight	Approx. 600g (including batteries and case lid)		
Accessories	7095A(Earth resistance test leads [red-20m, yellow-10m, green-5m/1set]) 7127A(Simplified measurement probe), 8032(Auxiliary earth spikes[2 spikes/1set]), 9121(shoulder strap), R6(AA) × 6, Instruction manual Carrying case : 9084[Soft] : 9164[Hard]		
Optional	7100A(Precision measurement Cord set), 8259(Adapter for measurement terminal)		

MODEL 4102A Soft case model

MODEL 4102A-H Hard case model

KEW 4105A



CE

4105A/4105A-H			
Earth resistance measurement	20Ω	200Ω	2000Ω
Measuring range	0.00 - 1999 Ω		
Display range	0.00 - 19.99 Ω	0.0 - 199.9 Ω	0 - 1999 Ω
Accuracy	±2%rdg±0.1 Ω	±2%rdg±3dgt	
Earth voltage measurement			
Measuring range	0 - 200 V AC (50,60Hz)		
Display range	0.0 - 199.9 V		
Accuracy	±1%rdg±4dgt		
Overload protection	Earth resistance : 280V AC (10 seconds) Earth voltage : 300V AC (1 minute)		
Applicable Standards	IEC 61010-1 CAT III 300 V Pollution degree 2 IEC 61010-2-030, IEC 61557-1, -5, IEC 60529 IP54, EN50581(RoHS)		
Power source	R6(AA)(1.5V) × 6		
Dimensions	105(L) × 158(W) × 70(H) mm (including case lid)		
Weight	Approx. 550g (including batteries and case lid)		
Accessories	7095A(Earth resistance test leads [red-20m, yellow-10m, green-5m/1set]) 7127A(Simplified measurement probe), 8032(Auxiliary earth spikes[2 spikes/1set]), 9121(shoulder strap), R6(AA) × 6, Instruction manual Carrying case : 9084 [Soft] : 9165[Hard]		
Optional	7100A(Precision measurement Cord set), 8259(Adapter for measurement terminal)		

KEW 4105A Soft case model

KEW 4105A-H Hard case model

- In addition to the facility for precision measurement, test leads for simplified two wire measuring system also supplied as standard accessories. (unit can be hung from the neck for simplified measurement)
- The latest circuit design permits the instrument to operate with the minimum of influence from earth voltage and earth resistance of auxiliary earth spikes.
- Dust and drip proof. (designed to IEC 60529 IP54)
- Earth resistance value can be read directly from the scale.
- Designed to meet IEC 61010-1 safety standard.
- Capable of measuring earth voltage.
- Small and lightweight. Shock resistant new case material.
- 2mA measuring current permits earth resistance tests without tripping earth leakage current breakers in the circuit under test.
- Lead wire connection to C and P terminals and proper auxiliary earth resistance can be checked by "OK" lamp. Lead wire connection to C and E terminals is good when "OK" lamp is illuminated. (4102A)

Optional Accessories

MODEL 7100A

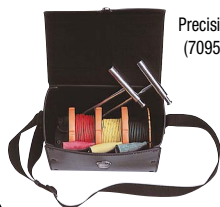

Precision measurement cord set
(7095A, 8032, 8200-03, 9091)

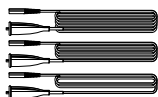

MODEL 7095A

Test leads for earth resistance



MODEL 8032

Auxiliary earth spikes
[2 spikes/1set]



MODEL 8200-03

Cord reels[3 pcs]

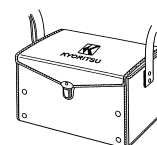

MODEL 9091

Carrying case for cord reels



Soft case model



Hard case model

EARTH TESTERS



KEW 4106



- Earth resistance measurement with six ranges covering measurements from 0.001 Ω to 200 kΩ.
- Earth resistivity (ρ) measurement is automatically calculated after having set the distance between Auxiliary Earth Spikes (Wenner method).
- Automatic and Manual selection of the Test Current Frequency in four bands of 94/105/111/128Hz. In Automatic mode KEW 4106 will select the most suitable Frequency.
- Advanced Filtering method (based on FFT Fast Fourier Transform) reduces noise interference for obtaining stable measurements.
- Up to 800 measurement results can be saved in the memory and recalled on the display.
- The stored results can be transferred to a PC via USB adaptor (Model 8212-USB) by using software "KEW Report" which are included.
- Robust design with IP54 protection.

		4106			
Function	Range	Resolution	Measuring range	Accuracy	
Earth resistance Re (Rg at ρ measurement)	2Ω	0.001Ω	0.03 - 2.099Ω	±2%rdg.±0.03Ω	
	20Ω	0.01Ω	0.03 - 20.99Ω		
	200Ω	0.1Ω	0.3 - 209.9Ω		
	2000Ω	1Ω	3 - 2099Ω	±2%rdg.±5dgt	
	20kΩ	10Ω	0.03k - 20.99kΩ		
	200kΩ	100Ω	0.3k - 209.9kΩ		
Auxiliary earth resistance Rh, Rs				8% of Re+Rh+Rs	
Earth resistivity ρ	2Ω	0.1Ω·m - 1Ω·m Autoranging	0.2 - 395.6Ω·m	ρ=2×π×a×Rg	
	20Ω		0.2 - 3956Ω·m		
	200Ω		20 - 39.56kΩ·m		
	2000Ω		0.2 - 395.6kΩ·m		
	20kΩ		2.0 - 1999kΩ·m		
	200kΩ				
Series interference voltage Ust (A.C only)	50V	0.1V	0 - 50.9Vrms	±2%±2dgt	
Frequency Fst	Autoranging	0.1Hz, 1Hz	40Hz - 500Hz	±1%±2dgt	
Test Current	80mA(max)				
Memory capacity	800 data				
Communication interface	Model 8212-USB Optical Adaptor				
LCD	Dot-matrix 192 × 64, monochrome				
Over-range indication	"OL"				
Overload protection	between E-S(P) and between E-H(C) terminals AC280V / 10 sec				
Applicable Standards	IEC 61010-1 CAT IV 150V, CAT III 300V Pollution degree 2 IEC 61557-1,-5, IEC 61326-1(EMC), IEC 60529(IP54)				
Power source	DC12V : sizeAA manganese dry battery (R6) x 8 (Auto power off: approx. 5 minutes)				
Dimensions	167(L) × 185(W) × 89(D)mm				
Weight	approx. 900g (including batteries)				
Accessories	7229A(Earth resistance test leads), 7238A(Simplified measurement test leads) 8032(Auxiliary earth spikes[2spikes/set])×2, 8200-04(Cord reels [4pcs]), 8212-USB(USB adaptor with "KEW Report(Software)") 9121(Shoulder strap), 9125(Carrying case) R6×8, Instruction manual				
Optional	8212-RS232C(RS232C adaptor with "KEW Report(Software)")				



KEW 4300

SIMPLIFIED EARTH TESTER



		4300
Earth resistance ranges		200.0/2000Ω(Auto ranging) ±3%rdg±5dgt
Voltage ranges		AC:5.0 - 300.0V(45 - 65Hz) ±1%rdg±4dgt DC:±5.0 - 300.0V ±1%rdg±8dgt
Applicable Standards		IEC 61010-1 CAT III 300V pollution degree 2 IEC 61557-1,-5 IEC 61326-1,-2-2,IEC 60529(IP40)
Power source		Size AA alkaline battery x 2 pcs
Dimensions		232(L) x 51(W) x 42(D)mm
Weight		220g approx(including battery)
Accessories		7248(Test lead with Alligator clip and Flat test probe) 8072(CAT II Standard prod) 8253(CAT IV Standard prod) 8017(Extension prod long) 9161(Carrying case) Instruction manual, LR6(AA)×2

KEW4300 is simplified earth resistance tester (based on 2-pole method) that can be used for various distribution lines and electrical appliances and it also can measure AC/DC voltage. (As for AC voltages, true rms values can be obtained.)

- 200/2000Ω (2 ranges) : auto-ranging.
- Warning buzzer triggered at 100Ω or less.
- LED lights up when a large earth voltage is detected.
- Live circuit warning when 30V or higher voltage is detected. (KEW4300 detects voltage even when measuring resistances.)
- LED light for illuminating measurement points. (It turns on/off automatically in relation to the ambient brightness.)
- Small test current (max 2mA) not triggering RCD.

EARTH CLAMP TESTERS

MODEL 4200/KEW 4202



photo : 4202

Note: A single earthing can not be measured. (Only for Multiple Earthing system)

- The earth resistance from 0.05 to 1500Ω can be measured without the auxiliary earth spikes in multi-earthing systems
- True RMS leakage or phase current readings from 0.1mA to 30.0A provides vital additional information in earthing networks
- Filter function offers increased immunity to electrical noise and a Noise mark appears in excessively high noisy environments
- Memory function up to 100 data
- Bluetooth communication (4202 only)

	4200	4202
Earth resistance Auto range	20.00/200.0/1500Ω ±1.5%±0.05Ω(0.00 - 20.99Ω)* ±2%±0.5Ω(16.0 - 99.9Ω) ±3%±2Ω(100.0 - 209.9Ω) ±5%±5Ω(160 - 399Ω) ±10%±10Ω(400 - 599Ω) Values are displayed, but accuracy isn't guaranteed(600 - 1580Ω)	
AC current (50Hz/60Hz) Auto range	100.0/1000mA/10.00/30.0A ±2%±0.7mA(0.0 - 104.9mA) ±2%(80mA - 31.5A)	
Operating indication	Earth resistance function : Constant voltage injection Current detection (Frequency : Approx.2400Hz) Dual Integration AC current function : Successive approximation	
Over-range indication	"OL" is displayed when input exceeds the upper limit of a measuring range	
Response time	Approx. 7 seconds (Earth resistance) Approx. 2 seconds (AC current)	
Sample rate	Approx. 1 times per second	
Communication Interface	—	Bluetooth Ver2.1 + EDR Class2
Power source	DC6V : R6(sizeAA manganese battery) x 4 or LR6 (sizeAA alkaline battery) x 4	
Current consumption	Approx. 50mA (max.100mA)	Approx. 50mA (max.100mA)
Measurement time	Approx.12 hours (when R6 is used) Approx.24 hours (when LR6 is used)	Approx.5 hours (when R6 is used) Approx.21 hours (when LR6 is used)
Auto power-off	Turns power off about 10 minutes after the last button operation.	
Applicable Standards	IEC 61010-1 CAT IV 300V Pollution degree2 IEC 61010-2-032, IEC 61326 (EMC)	
Conductor size	Approx. φ32mm	
Dimension	246(L)×120(W)×54(D)mm	
Weight	Approx. 780g (including batteries)	
Accessories	R6 x 4, Instruction manual 8304 (Resistor for operation check) 9166 (Carrying case[Hard])	LR6 x 4, Instruction manual 8304 (Resistor for operation check) 9167 (Carrying case[Hard])

*Crest factor ≤ 2.5 (50Hz/60Hz, peak value shall not exceed 60A)
*4 counts or less are corrected to 0.

Various useful functions are available on Android devices using Bluetooth communication(4202 only)

Free Android software "KEW Smart 4202" is available on download site



Download



KEW Smart 4202

※Communication charges may be incurred separately to download application

Recorded data can be transferred (up to 100 measurements)



Measurement results

Measured data with time and location info can be sent by E-mail

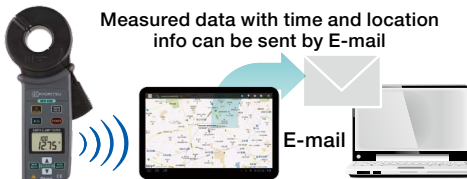

E-mail

GPS data collection may be lost since the GPS signal differs depending on the location of satellites.
To access GPS data and send emails, an Internet connection is required.
Communication charges may be incurred separately for using these functions.

Comparator function informs when the measured value is lower/higher than the preset value

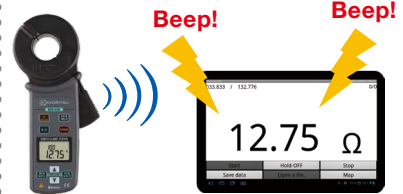

Beep!

Beep!

Accessories

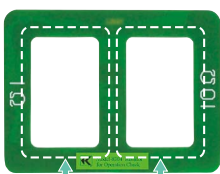

1Ω loop 10Ω loop

MODEL 8304

Resistor for operation check



MODEL 9167

Carrying case[Hard]



※Available on the Android devices equipped with Bluetooth/ GPS/ Data communication function Supporting Android ver. 2.2 - 4.4
Max communication distance :10m
Bluetooth is a registered trademark of the Bluetooth SIG, Inc.
Android is a registered trademark of the Google Inc.

Earth Clamp Line up

	4200	4202
Common functions	Earth resistance, AC current, Back light function, Data hold function, Auto power off, Memory function	
Individual functions	—	Bluetooth communication

LOOP/PSC TESTERS

MODEL 4118A



- Custom microprocessor controlled for highest accuracy and reliability.
- 3 LEDs for checking correct wiring status.
- 15mA LOOP measurement: LOOP impedance 2000Ω range measurement is carried out with low test current (15mA). The current will not cause tripping out involved RCD even the one with the lowest nominal differential current (30mA).
- Direct reading of Prospective Short Circuit Current (PSC).
- Measure low loop resistances (resolution of 0.01Ω)
- Automatic lock-out if test resistor overheats.
- Large custom digital display readout .
- Visual indication of reversed phase and neutral wiring at socket.
- Designed to IP54 Rating

	4118A
Loop impedance ranges	20/200/2000Ω
Loop impedance accuracy	±2%rdg±4dgt
AC test current	20Ω 25A 200Ω 2.3A 2000Ω 15mA
AC test period	20Ω (20ms) 200Ω (40ms) 2000Ω (280ms)
PSC ranges	200A(2.3A 40ms) 2000A(25A 20ms) 20kA(25A 20ms)
PSC ranges accuracy	Consider accuracy of loop impedance
Voltage	110V - 260V ±2%rdg±4dgt
Operating voltage	230V +10%, -15%(195V - 253V)50Hz
Applicable Standards	IEC 61010-1 CAT III 300V Pollution degree 2 IEC 61557-1,3, IEC 60529(IP54)
Dimensions	167(L) × 185(W) × 89(D)mm
Weight	750g approx.
Accessories	Molded plug test leads* 7121B(Distribution board test leads) 9147(Cord case) 9121(Shoulder strap) Instruction manual

* 7123(AU): Australian plug 7124(UK): British plug(13A)
7125(EU): European SHUKO plug 7126(SA): South african plug

Accessories



MODEL 7121B
(Distribution board test leads)



Molded plug test leads

- MODEL 7123** (AU) Australian plug
- MODEL 7124** (UK) British plug(13A)
- MODEL 7125** (EU) European SHUKO plug
- MODEL 7126** (SA) South african plug

Loop Testing Methods

In the buildings mainly used for private residence where low voltage power is supplied from electric utilities the fundamental protection against electric shock hazards is provided by appropriately coordinating the function of an earthing circuit with automatic switches placed at the latter stage of indoor wiring circuits. This is intended to quickly cut off the supply to an earthing circuit where a fault occurs following touch voltage exceeding an acceptable limit. Proper protection against electric shock hazards is given when the TT wiring system satisfies the requirement as expressed by the following formula:

$$R_a \times I_a \leq 50$$

where R_a is the sum of the resistances of earth bars and protective conductors and I_a is the maximum current of a protection system provided for installations, indicating that the value obtained by multiplying R_a with I_a is not more than 50V. This means a maximum voltage one can touch shall not exceed 50V in the event of an earth fault.

- Method of earth fault loop impedance testing at socket outlet. As shown in Fig., total earth fault loop impedance can be measured by plugging a loop tester into socket. The value of earth fault loop impedance measured represents the sum of transformer coil winding resistance, phase conductor (L3) resistance and protective conductor (PE) resistance as well as source earth resistance and installation earth resistance. With the loop tester set to any one of the PSC (prospective short circuit current) range, it is also possible to measure earth fault current.

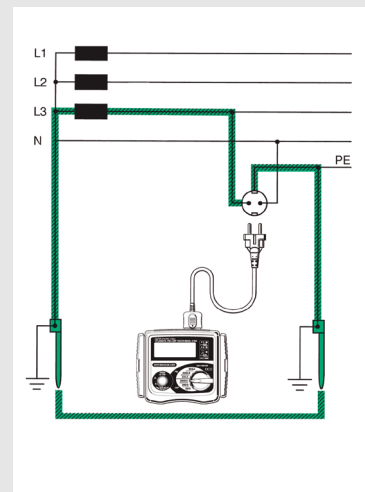

Fig. Earth fault loop impedance testing at socket outlet.

LOOP/PSC TESTERS

KEW 4140



- Anti-Trip Technology for complete trip free Loop testing on all RCDs rated 30mA and above.
- Dual Display allows simultaneous measurements like Loop & PFC/PSC.
- Two wire connection for Loop L-L, L-N and PSC testing is possible.
- Phase rotation, Voltage and Frequency measurements.
- Lock-down test button for 'hands free' testing with auto-start operation.
- Display and front panel keyboards with Backlight to be visible in dark places.
- Water and Dust proof (IP54)



4140			
Loop Impedance			
Function	L-PE ATT OFF	L-PE ATT ON	L-N/L-L
Rated voltage	230V (50/60Hz)		L-N: 230V (50/60Hz) L-L: 400V (50/60Hz)
Operating Voltage	100 - 280V (45 - 65Hz)		100 - 500V (45 - 65Hz)
Range (Auto-Ranging)	20/200/2000Ω	20/200/2000Ω (L-N<20Ω)	20Ω
Nominal Test Current at 0Ω External Loop: Magnitude/Duration at 230V	20Ω:6A/40ms 200Ω:2A/20ms 2000Ω:15mA/500ms	L-N:6A/60ms N-PE:10mA/approx. 5s	20Ω:6A/20ms
Accuracy	±3%rdg±4dgt (*1)	±3%rdg±6dgt (*1)	L-N: ±3%rdg±4dgt L-L: ±3%rdg±8dgt
PFC(L-PE)/PSC(L-N/L-L) (*2)			
Function	PSC	PFC (ATT)	PSC
Rated voltage	230V (50/60Hz)		L-N: 230V (50/60Hz) L-L: 400V (50/60Hz)
Operating Voltage	100 - 280V(45 - 65Hz)		100 - 500V(45 - 65Hz)
Range (Auto-Ranging)	2000A/20kA	2000A/20kA(L-N<20Ω)	2000A/20kA
Nominal Test Current at 0Ω External Loop: Magnitude/Duration at 230V	20Ω:6A/40ms 200Ω:2A/20ms 2000Ω:15mA/500ms	L-N:6A/60ms N-PE:10mA/approx. 5s	20Ω: 6A/20ms
Phase Rotation			
Operating Voltage	50 - 500V, 45 - 65Hz		
Remarks	Correct phase sequence : displayed "1.2.3" and ⌚ mark Reversed phase sequence : displayed "3.2.1" and ⌚ mark		
Volts			
Function	Volts		Frequency
Measuring range	0 - 500V		45 - 65Hz
Accuracy	±2%rdg±4dgt		±0.5%rdg±2dgt
Applicable Standards	IEC 61010-1 CAT III 300V (500V L to L) IEC 61557-1,3,7,10, IEC 60529 (IP54), IEC 61326(EMC)		
Power source	1.5V AA batteries × 6 *Use of alkaline batteries (LR6) is recommended.		
Dimensions	84(L) × 184(W) × 133(D)mm		
Weight	860g (including batteries.)		
Accessories included	Main test lead (*3), Distribution board test lead (*4), 9155 (shoulder strap), 9156 (Soft case) LR6 (Battery) × 6, Instruction manual		

*1: Accuracy of L-N LOOP displayed on the Sub Display is synchronized with the one at L-N/L-L function.

*2: PSC/PFC Accuracy is derived from measured loop impedance specification and measured voltage specification.

*3: 7187A:(UK)British plug, 7218A:(EU)European SHUKO plug, 7221A:(SA)South african plug, 7222A: (AU)Australian plug

*4: 7246 : Blue, Green, Red, 7247 : Black, Green, Red

Accessories



Main test lead

MODEL 7187A

MODEL 7218A (EU)European SHUKO plug

MODEL 7221A (SA)South african plug

MODEL 7222A (AU)Australian plug



Distribution board test lead

MODEL 7246 Blue, Green, Red

MODEL 7247 Black, Green, Red



MODEL 9156

Soft case

RCD TESTERS

MODEL 5406A



CE

	5406A
Rated tripping current	10/20/30/200/300/500mA
Fault condition settings	× 1/2 × 1 × 5 × DC Auto Ramp
Trip current duration	1000ms 200ms(× 5)
Lowest resolution	1ms
Trip time accuracy	±0.6%rdg±4dgt
Operating voltage	230V+10%-15% (195V - 253V)[50Hz]
Applicable Standards	IEC 61557-1,6 IEC 61010-1 CAT III 300V IEC 61010-031 Pollution degree 2 IEC 60529(IP54)
Dimensions	167(L) × 186(W) × 89(D)mm
Weight	800g approx.
Accessories	Molded plug test leads*, 9147(Cord case) 9121(Shoulder strap), Instruction manual
Optional	7121B(Distribution board test leads)

* 7123(AU) : Australian plug 7124(UK) : British plug(13A)
7125(EU) : European SHUKO plug 7126(SA) : South african plug

- Custom microprocessor controlled for highest accuracy and reliability.
- 3 LEDs for checking correct wiring status.
- 0 and 180 degree phase angle switch permits quick tests and consistent readings.
- Digital read-out of tripping time.
- Test of a large kind of RCDs : Standard, Selective, AC and A(DC sensitive breakers).
- Constant current source circuitry ensures that a fluctuating mains voltage does not affect the accuracy of readings.
- Large custom digital display readout .
- Visual indication of reversed phase and neutral wiring at socket.
- Designed to IP54 Rating.
- Complies with IEC 61557

Accessories



Molded plug test leads

MODEL 7123 (AU)Australian plug

MODEL 7124 (UK)British plug(13A)

MODEL 7125 (EU)European SHUKO plug

MODEL 7126 (SA)South african plug

RCD TESTERS

KEW **5410**



CE

- Measurement of RCD trip time**
 Conducting testing of rated residual non-operating currents at x 1/2 Range, measuring RCD trip time at x1 and x5 Ranges.
- Measurement of trip out current**
 Measuring trip out current by varying current automatically.
- Remote Test**
 Enabling a user to hold the Test Leads with his both hands by locking the Test Button. Measurement will automatically start when the main voltage is detected.
- Voltage Measurement**
 Carrying out a constant measurement of voltage in the stand-by mode at each Range.
- Auto-detection of Contact voltage**
 Detecting the voltage to earth of Earth electrodes or Protective conductors during RCD test - when applying test currents - at measurement using EARTH in order to prevent electrical shocks caused by the damaged earth. Measurement will be ceased at AC50V or more.
- Dust- and Water-proof**
 Dust- and Water-proof construction. (designed to IEC 60529 IP54)
- Backlight**
 Facilitating working at dimly illuminated locations.

		5410			
Measurement of RCD trip time		Measurement of trip out current			
Range		x5	x1	x1/2	Auto Ramp (mA)
Rated voltage		100V±10% 200V+32%/-10% 400V±10% (50/60Hz)			
Test current		15/30/50/100mA	15/30/50/100/200/500mA	15/30/50/100/200/500mA	
Measuring range		Testing time 200ms	Testing time 2000ms	Testing time 2000ms	40% - 110% of I _{Δn} (goes up by 5%) Testing time 300ms x 15 steps
Accuracy	Trip time	±1%rdg±3dgt	±1%rdg±3dgt	±1%rdg±3dgt	Test current at each step
	Test current	+2% - +8%dgt	+2% - +8%dgt	-8% - -2%dgt	-4% - +4%
Voltage measurement					
Measuring range	80V - 450V(50/60Hz)				
Accuracy	±2%rdg±4dgt				
Applicable Standards	IEC 61010-1 Pollution degree 2 CAT III 300V/ CAT II 400V IEC 61557-1,6 IEC 60529(IP54)				
Display	1999 counts(3 1/2digits), Large LCD				
Operating temperature & humidity	0°C - 40°C, relative humidity 85%(no condensation)				
Storage temperature & humidity	-20°C - 60°C, relative humidity 85%(no condensation)				
Insulation resistance	50MΩ or more / 1000V(between electrical circuit and enclosure)				
Power source	DC12V / Size AA battery R6(SUM-3)×8pcs				
Dimension	167(L)×186(W)×89(D)mm				
Weight	Approx. 965g (including batteries)				
Accessories	7128A(Test leads), 7129A(Test lead with alligator clip) 8017(Extension prod)×2 9147(Cord case), 9121(Shoulder strap), Instruction manual, R6(SUM-3)(AA)×8				

*Only the RCD type G (without trip out time-delay) can be tested at Auto Ramp Test ; type S (time-delay) cannot be tested.

Accessories

MODEL 7128A
Test leads

MODEL 7129A
Test lead with alligator clip

MODEL 8017
Extension prod

Neutral - Line

Connect the "PRIMARY" of the Connector Block to the Neutral of the power of RCD, and the "SECONDARY" of the Connector Block to the Line of the load of RCD.

Line - Line

Connect the "PRIMARY" of the Connector Block to L2 of the power of RCD, and the "SECONDARY" of the Connector Block to L1 of the load of RCD.

Earth - Line

Connect the "PRIMARY" of the Connector Block to Earth, and the "SECONDARY" of the Connector Block to Line of the load of RCD.

PORTABLE APPLIANCE TESTER

KEW 6201A



The KEW 6201A is a portable appliance tester, performing four functions to ensure the Safety of Class I and Class II appliances. And also can measure the mains voltage.

Readings are displayed on a large liquid crystal display (LCD) below which are four LEDs which unambiguously display a pass or fail indication for threshold values dictated by AS/NZS 3760.

This instrument is suitable for performing tests as required by the following standards. AS/NZS 3760 In-service safety inspection and testing of electrical equipment.

		6201A
RPE 20Ω Protective Conductor Resistance Test		
Measuring range	0 - 15.00Ω	
Open circuit voltage	< AC 12V	
Measuring current	10A AC nominal value	
Accuracy	±3%rdg±5dgt	
RINS 200MΩ Insulation Resistance		
Rating	250V/20MΩ	500V/20MΩ
Measuring range	0 - 19.99MΩ	
Output Voltage	250V DC (+20%/-10%) @1MΩ	500V DC (+20%/-10%) @1MΩ
Short circuit current	2.5mA DC or less	
Accuracy	±2%rdg±3dgt	
Leakage Current Test		
Measuring range	AC 0.1 - 19.99mA	
Examination time	Max 15 seconds	
Accuracy	±3%rdg±5dgt	
AC VOLT Mains Voltage Check		
Measuring range	207 - 264V	
Accuracy	±2%rdg±3dgt	
Supply Voltage	240V±10%	
Frequency	50Hz±1%	
Applicable Standards	IEC 61010-1 CAT III 300V Pollution Degree2, IEC 61326-1(EMC)	
Dimensions	167 (L)× 185 (W) × 89 (D) mm	
Weight	1.2kg (only the instrument body)	
Accessories	7123(Power cord [AU]), 7129A(Test leads with Alligator clip) 7161A(Flat test prod), 7140(Adapter for Extension Cord) 9147(Cord case), 9121(Shoulder strap), Instruction manual	
Optional	7121B (Distribution board test leads)	

Test Function

Function	Tests of contents
Class I Test	<ul style="list-style-type: none"> Protective conductor resistance Insulation (250V or 500V)
SELECT Switch + Class I Test	<ul style="list-style-type: none"> Protective conductor resistance Leakage Current test
Class II Test	<ul style="list-style-type: none"> Insulation (250V or 500V)
SELECT Switch + Class II Test	<ul style="list-style-type: none"> Leakage Current test
Extension Leads test	<ul style="list-style-type: none"> Protective conductor resistance Insulation P/N-PE Polarity
SELECT Switch + Extension Leads test	<ul style="list-style-type: none"> Protective conductor resistance Leakage Current test
Leakage Current Test	<ul style="list-style-type: none"> Leakage current measurement

Accessories



Optional Accessory



MULTI FUNCTION TESTERS

MODEL 6018

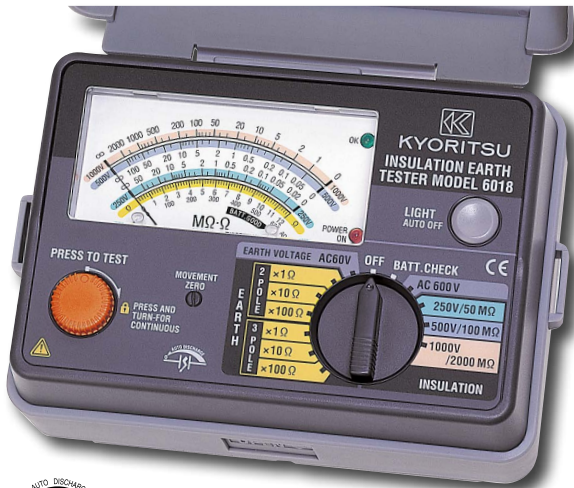

3 in 1

Insulation

250/500/1000V

ACV

600V

Earth

2/3 POLE 12/120/1200Ω

	6018
Insulation testing	
Test voltage	250V/50MΩ 500V/100MΩ 1000V/2000MΩ
Accuracy	±5%rdg
Earth resistance	
Simplified precision measurement	12Ω/120Ω/1200Ω
Accuracy	±3% of full scale value
AC voltage	
0 - 600V AC	±3% of full scale value
Earth voltage	
0 - 60V AC	±3% of full scale value
General	
Applicable Standards	IEC 61010-1 CAT III 600V pollution degree 2 IEC 61010-031 IEC 61557
Power source	R6(AA)× 8
Dimensions	130(L) × 183(W) × 100(D)mm
Weight	1000g approx. (including batteries)
Accessories	7103A (Test leads with remote control switch) 7161A (Flat test prod) 7131B (Safety crocodile clips [black]) 8017 (Extension prod) 9092 (Cord case) 9121 (Shoulder strap) R6(AA)× 8 Instruction manual
Optional	7100A (Precision measurement cord set) 7115 (Extension probe) 8016 (Hook type prod)

Accessories

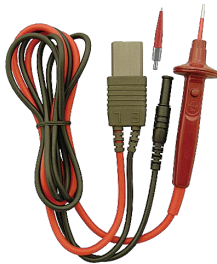

MODEL 7103A

Test lead with remote control switch
Line 1,000mm / Earth 1,550mm



MODEL 7131B

Safety crocodile clip



MODEL 7161A

Flat test prod



MODEL 8017

Extension prod

Optional Accessories



Plug



MODEL 7100A

Precision measurement cord set
(7095A, 8032, 8200-03, 9091)

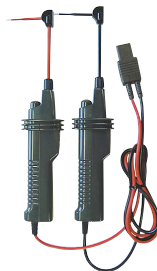

MODEL 7115

Extension probe



MODEL 8016

Hook type prod

MULTI FUNCTION TESTERS

KEW 6010B

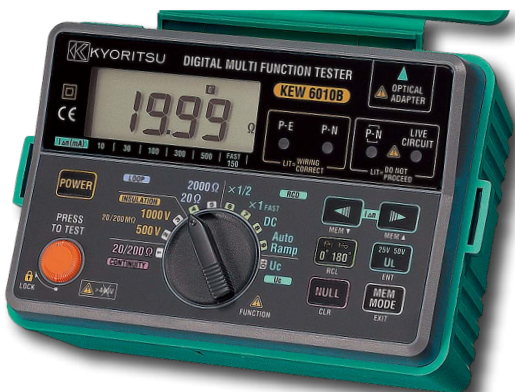

- Designed to IEC 61010-1, IEC 61557
- Data Memory : 300 measured results
- Download Results to PC by Using 8212 Data Communication Adaptor through Optical RS-232C Port.

5 in 1

Continuity

20/200Ω

Loop

20/2000Ω

Uc

100V

Insulation

500/1000V

RCD

10/30/100/300/500mA

Accessories

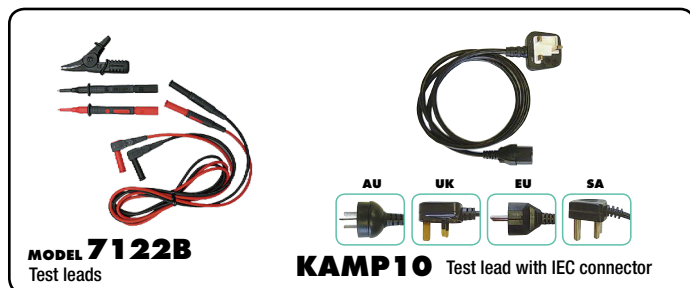

MODEL 7122B
Test leads

MODEL KAMP10 Test lead with IEC connector

		6010B
Continuity testing		
Measuring range		20/200Ω (Auto-ranging)
Open circuit voltage		>6V
Short circuit current		>200mA
Accuracy		±(3%rdg+3dgt)
Insulation resistance testing		
Measuring range		20/200MΩ(Auto-ranging)
Test voltage		500/1000V
Open circuit voltage		+20%, -0%
Rated current		>1mA
Accuracy		±(3%rdg+3dgt)
LOOP Impedance testing		
Impedance range		20Ω/2000Ω
Rated voltage		230V +10%, -15% [50Hz]
Normal test current		20Ω: 25A/10ms 2000Ω: 15mA/350ms max.
Accuracy		±(3%rdg+8dgt)
RCD testing		
Test current (Test current duration)	×1/2, ×1	10, 30, 100, 300, 500mA (2000ms)
	FAST	150mA(50ms)
	DC	10,30,100,300mA (2000ms), 500mA(200ms)
	Auto ramp	Goes up by 10% from 20% to 110% of IΔn. 300ms × 10
Rated voltage		230V+10%, -15% 50Hz
Accuracy	Test current	× 1/2 : -8%, -2% × 1, Fast : +2%, +8%
	Trip time	DC : ±10% Auto ramp: ±4%
		±(1%rdg+3dgt)
Uc testing		
Measuring range		100V
Rated voltage		230V +10%, -15% [50Hz]
Test current		5mA at IΔn=10mA
		15mA at IΔn=30/100mA
		150mA at IΔn=300/500mA
Accuracy		+5% to +15%rdg±8dgt
General		
Applicable Standards		IEC 61010-1 CAT III 300V Pollution degree 2 IEC 61557-1,2,3,4,6,10, IEC 60529 (IP40)
Power source		R6 or LR6 × 8
Dimensions		115(L) × 175(W) × 86(D) mm
Weight		840g approx.
Accessories		7122B (Test leads) KAMP10 (Test lead with IEC connector)* 9092 (Cord case) 9148 (Shoulder strap) Shoulder pad Instruction manual R6(AA)× 8
Optional		7133B (Distribution board test leads) 8212-RS232C (RS232C adaptor with "KEW Report (Software)") 8212-USB (USB adaptor with "KEW Report (Software)")

* KAMP10(EU):European SHUKO plug KAMP10(UK):British plug(13A)
KAMP10 (AU):Australian plug KAMP10(SA):South african plug

Optional Accessories

MODEL 8212-USB

USB adaptor with "KEW Report (Software)"



MODEL 8212-RS232C

RS232C adaptor with "KEW Report (Software)"



MODEL 7133B

Distribution board test leads



Specifications

	MODEL 8212-USB	MODEL 8212-RS232C
Communication method	USB Ver1.1	-
Driver type	Virtual COM port	-
Communication speed	19200bps max.	9600bps max.
Dimensions	Adaptor : 53(L)×36(W)×19(D)mm Cable : 2m approx.	Adaptor : 61(L)×36(W)×19(D)mm Cable : 1.6m approx.
Operating temperature and humidity	-10 - +50°C 85%RH or less with no condensation	0 - +40°C 85%RH or less with no condensation
Storage temperature and humidity	-20 - +60°C 85%RH or less with no condensation	

System Requirements

OS: Windows® Vista/7/8/10 Hard-disk: Space required 20Mbyte or more
Display: XGA (Resolution 1024 x 768 dots) or more Others: With CD-ROM drive and USB port

*Windows® is a registered trade mark of Microsoft in the United States.

"KEW Report" Software for report
"KEW Report" transfers measurement data from the KEW6010B to a PC via MODEL8212-USB or MODEL8212-RS232C.

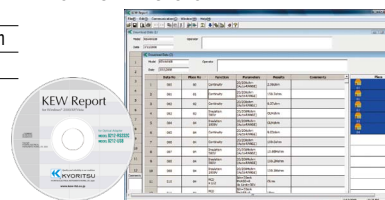

MULTI FUNCTION TESTERS

MODEL 6011A

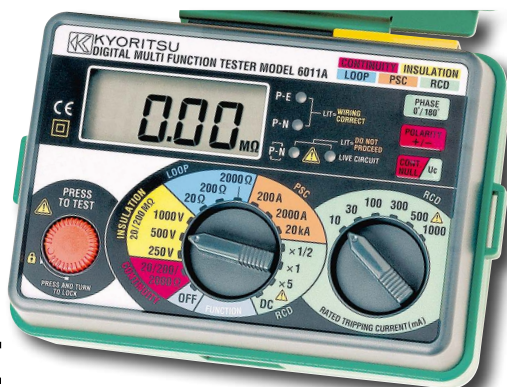

CE

The Model 6011A can perform FIVE separate test functions: insulation, continuity, earth loop impedance, prospective short circuit current and RCD trip testing in full compliance with IEC 61557.

5 in 1

Continuity

20/200/2000Ω

Loop

20/200/2000Ω

PSC

200/2000/20kA

Insulation

250/500/1000V

RCD

10/30/100/300/500/1000mA

	6011A
Continuity testing	
Measuring ranges	20/200/2000Ω(Autoranging)
Open circuit voltage	>6V
Short circuit current	>200mA DC
Accuracy	±(1.5%rdg+3dgt)
Insulation testing	
Measuring ranges	20/200MΩ(Autoranging)
Test voltage	250/500/1000V DC
Output voltage on open circuit	250V+40%, -0% 500+30%, -0% 1000V+20%, -0%
Rated current	> 1mA
Accuracy	±(1.5%rdg+3dgt)
Loop impedance testing	
Rated voltage	230V AC +10%, -15%[50Hz]
Voltage measuring range	100 - 250V AC[50Hz]
Impedance ranges	20/200/2000Ω
Nominal test current	25A(20Ω range) 15mA(200Ω range) 15mA(2000Ω range)
Accuracy	20Ω range ±(3%rdg+4dgt) 200Ω range ±(3%rdg+8dgt) 2000Ω range ±(3%rdg+4dgt)
PSC testing	
Rated voltage	230V AC +10%, -15%[50Hz]
PSC ranges	200A(15mA Test current) 2000A(25A Test current) 20kA(25A Test current)
Accuracy	PSC accuracy derived from measured loop impedance specification and measured voltage specification
RCD testing	
Rated voltage	230V AC +10%, -15%[50Hz]
Trip current settings	RCD x 1/2 :10,30,100,300,500,1000mA RCD x 1 : 10,30,100,300,500,1000mA RCD x 5 : 10,30,100,300mA (on x 5 range max current 1A)
Trip current duration	RCD x 1/2 x 1 : 2000ms RCD fast : 50ms
Accuracy	Trip current +10% -0% of test current at 230V Trip time ±(1%rdg + 3dgt)
General	
Applicable Standards	IEC 61010-1 CAT III 300V pollution degree 2 IEC 61557 IEC 60529(IP54)
Power source	R6 or LR6 x 8
Dimensions	130(L) x 183(W) x 100(D)mm
Weight	1100g approx.
Accessories	KAMP10(Test lead with IEC connector)* 7122B(Test leads), 7132A(KSLP5)(External earth probe) 9092(Cord case), 9121(Shoulder strap) R6(AA) x 8, Instruction manual
Optional	7133B(Distribution board test leads)

* KAMP10(EU): European SHUKO plug KAMP10(UK):British plug(13A)
KAMP10(AU):Australian plug KAMP10(SA):South african plug

Accessories

KAMP 10
Test lead with IEC connector

MODEL 7122B
Test leads

MODEL 7132A (KSLP5)
External earth probe (6011A only)

Optional Accessory

MODEL 7133B (OMA DIEC)
Distribution board test leads

MULTI FUNCTION TESTERS

KEW 6016

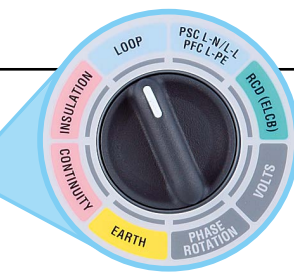

A single rotary dial to make your selection.



Slim remote probe with test button as well as a lockdown option on the instrument for the most convenient hands free testing.



Continuity Measurement

Continuous testing can be carried out by use of the test button lockdown feature. A selectable buzzer gives instantaneous indication of continuity. Null facility eliminates the test lead resistance from the results, the nulled value is retained even if the instrument is switched off. Live circuit warnings are given by a flashing LED, buzzer and indication on the display.

Insulation Measurement

Three selectable test voltages 250V, 500V and 1000V. An auto-discharge function ensures that circuits are not hazardous after testing. A red LED gives warning of high voltage output during testing and discharging of the circuit. In case of connecting to a live circuit, a live circuit warning is given by flashing LED, buzzer and indication on the display.

Loop Impedance Measurement

A patented (ATT) low current loop impedance test enables high accuracy loop measurements (up to 0.01 ohm) and quick testing without tripping RCDs. A high current alternative is selectable for even higher accuracy and instantaneous results. The subsequent test will default to the low current test, this saves any inadvertent tripping of the RCD. The KEW6016 allows also for phase to phase loop tests.

PSC / PFC Measurement

The Prospective Short Circuit Current (PSC) and Prospective Fault Current (PFC) are automatically calculated and shown on the display. As loop testing, the function has low and high test current options with the default to low current to avoid inadvertent tripping of RCDs.

RCD Measurement

The KEW 6016 has a comprehensive RCD test feature for RCD type AC (Alternative Currents), RCD type A (Pulsating Direct Currents), General and Selective (delayed). Measures at 1/2 x, 1x, 5x of nominal RCD current. It also has Ramp Test and Auto test where all results are shown on one screen. Touch voltage limit can be selected for 25V or 50V depending on application.

Earth Measurement

Using the classical Volt-Amper method with two auxiliary earth spikes and without external power source. All test leads and spikes are supplied as standard accessories.

Phase rotation

KEW 6016 can check the phase rotation of three phase lines with clear indication of the sequence on the display.

Voltage Measurement

In addition to the voltage measurement, this function gives also the Frequency of the voltage under test.

Memory Function

Save and display up to 1000data.

10 in 1

Continuity

20/200/2000Ω

Insulation

250/500/1000V

Loop

20/200/2000Ω

PSC

2000A/20kA

PFC

2000A/20kA

RCD

10/30/100/300/500/1000mA

Earth

20/200/2000Ω

ACV

500V

Phase rotation

Frequency

Hands Free Testing



The instrument features a test button in the probe and a lockdown test button for 'hands free' operation.

RCD (ELCB)-Auto Test

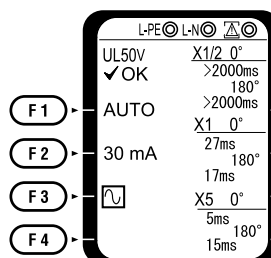

Auto test enables complete testing of RCD (6 tests) while the operator simply stands by and resets the RCD. All the results are displayed on one screen - no need to scroll.

MULTI FUNCTION TESTERS

6016

Continuity	
Range	20/200/2000Ω (Auto-ranging)
Open circuit voltage (DC)	5V±20% ^(*)
Short circuit current	>200mA
Accuracy	±0.1Ω (0 - 0.19Ω) ±2%rdg+8dgt (0.2 - 2000Ω)
Insulation resistance	
Range	20/200/2000MΩ (Auto-ranging)
Open circuit voltage (DC)	20/200MΩ: 250V+25% -0% 20/200/2000MΩ: 500V+25% -0%, 1000V+20% -0%
Rated current	20/200MΩ: 1mA or > @ 250kΩ 20/200/2000MΩ: 1mA or > @ 500kΩ, @ 1MΩ
Accuracy	20/200MΩ: ±2%rdg+6dgt (0 - 19.99MΩ) ±5%rdg+6dgt (20 - 200MΩ) 20/200/2000MΩ: ±2%rdg+6dgt (0 - 199.9MΩ) ±5%rdg+6dgt (200 - 2000MΩ)
Loop impedance	
Function	L-PE, L-PE (ATT), L-N / L-L
Rated voltage	L-PE, L-PE (ATT): 100 - 260V (50/60Hz) L-N: 100 - 300V (50/60Hz) L-L: 300 - 500V (50/60Hz)
Nominal test current at 0Ω external loop:	20Ω: 6A/20ms 200Ω: 2A/20ms 2000Ω: 15mA/500ms
Magnitude/Duration at 230V	L-N: 6A/60ms N-PE: 10mA/approx. 5s
Range	20/200/2000Ω Auto-Ranging (L-N < 20Ω)
Accuracy	L-PE, L-N / L-L: ±3%rdg+4dgt ^{*2} ±3%rdg+8dgt ^{*3} L-PE (ATT): ±3%rdg+6dgt ^{*2} ±3%rdg+8dgt ^{*3}
PSC (L-N/L-L) / PFC (L-PE)	
Function	PSC, PFC, PFC (ATT)
Rated voltage	PSC: 100 - 500V 50/60Hz PFC, PFC (ATT): 100 - 260V 50/60Hz
Nominal test current at 0Ω external loop:	PSC: 6A/20ms PFC: 6A/20ms, 2A/20ms, 15mA/500ms
Magnitude/Duration at 230V	PFC (ATT): L-N: 6A/60ms, N-PE: 10mA/approx. 5s
Range	2000A/20kA Auto-Ranging
Accuracy	PSC/PFC accuracy is derived from measured loop impedance specification and measured voltage pecification
RCD	
Function	X1/2, X1, X5, Ramp, Auto, Uc
Trip current setting	X1/2, X1, Uc: 10/30/100/300/500/1000mA X5: 10/30/100mA Ramp: 10/30/100/300/500mA

RCD		
Trip current Duration	X1/2:	2000ms
	X1:	G:550ms / S: 1000ms
	X5:	410ms
	Ramp:	Goes up by 10% from 20% to 110% G:300ms/S:500msX10 times
Rated voltage	X1/2, X1, X5, Ramp, Uc:	230V+10%-15% 50/60Hz
	Auto:	Depending on the accuracy at each function. Measurement sequence: X1/2 0°→X1/2 180°→X1 0°→X1 180°→X5 0°→X5 180° Measurements with x5 are not carried out for RCDs with nominal current of 100mA or more.
Accuracy	AC Type	X1/2: -8% - -2%, X1, X5: +2% - +8%, Ramp: ±4%
	A Type	X1/2: -10% - 0%, X1, X5: 0% - +10%, Ramp: ±10% Uc: +5% - +15%rdg±8dgt
Earth		
Range	20/200/2000Ω Auto-Ranging	
Accuracy	20Ω:	±3%rdg+0.1Ω
	200/2000Ω:	±3%rdg+3dgt (Auxiliary earth resistance 100±5%)
Phase Rotation		
Rated Voltage	50-500V 50/60Hz	
Remarks	Correct phase sequence: are displayed "1.2.3" and ◯ mark Reversed phase sequence: are displayed "3.2.1" and ◯ mark	
Volts		
Function	Volts	Frequency
Rated voltage	25 - 500V, 45 - 65Hz	
Measuring range	25 - 500V	45 - 65Hz
Accuracy	±2%rdg+4dgt	±0.5%rdg+2dgt
General		
Applicable Standards	IEC 61010-1 CAT III 300V(500V L to L) Pollution degree 2 IEC 61557-1,2,3,4,5,6,7,10 IEC 60529(IP40), IEC 61326(EMC)	
Power source	LR6 × 8	
Dimensions	136(L) × 235(W) × 114(D)mm	
Weight	1350g (including batteries.)	
Accessories	Main test lead ^{*1} 7196A(test leads with remote control switch) 7188A(Distribution board fused test leads) 7228A(Earth resistance test leads) 8032(Auxiliary earth spikes[2 spikes/set]) 8212-USB(USB adaptor with KEW Report(Software)) 9014(Cord case), 9142(Carrying Case), 9121(Shoulder strap), Buckle, Battery, Instruction manual 8212-RS232C(RS232C adaptor with KEW Report(Software))	
Optional	8212-RS232C(RS232C adaptor with KEW Report(Software))	

*1: Voltages are output when measurement resistance is under 2100 ohm.
*2: 230V+10%-15%
*3: Other voltages except for *2
*4: 7187A:British plug, 7218A:(EU)European SHUKO plug,
7221A(SA) South african plug, 7222A:(AU)Australian plug

Accessories



MODEL 7188A
Distribution board fused test leads



MODEL 7196A
Test leads with remote control switch



Main test lead



7187A
7221A
7218A
7222A
Plug



MODEL 7228A
Earth resistance test leads



MODEL 8032
Auxiliary earth spikes
[2 spikes/set]



MODEL 9142
Carrying Case

Optional Accessory



MODEL 8212-USB
USB adaptor with "KEW Report (Software)"



MODEL 8212-RS232C
RS232C adaptor with "KEW Report (Software)"

"KEW Report" Software for report
"KEW Report" transfers measurement data from the KEW6016 to a PC via MODEL8212-USB or MODEL8212-RS232C.



System requirements
OS: Windows® Vista/7/8/10
Display: XGA (Resolution 1024 x 768 dots) or more
Hard-disk: Space required: 20Mbyte or more
Others: With CD-ROM drive and USB port
* Windows® is a registered trademark of Microsoft in the United States.

PV INSULATION EARTH TESTER

KEW **6024PV** **NEW**

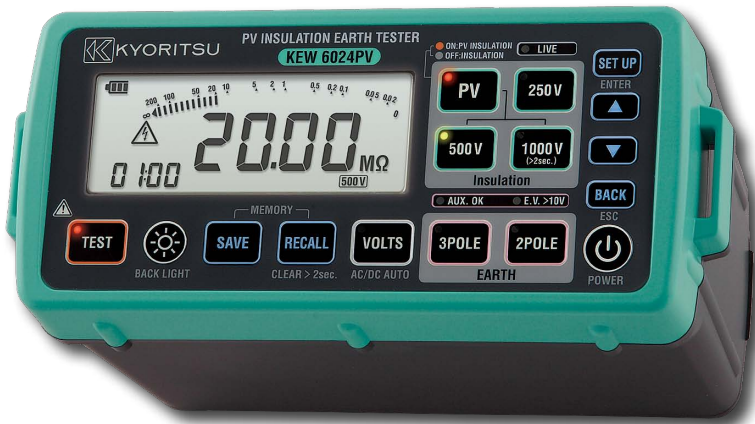

- Accurate measuring of Insulation resistance even if the PhotoVoltaic (PV) arrays are generating power.
- No need to short circuit the PV arrays or test at night to measure the Insulation resistance.
- Earth resistance measurements with VoltAmperometric method at 3 and 2 pole.
- Waterproof design: Can measure in bad weather conditions.
- Memory function up to 1000 data.
- Luminescence buttons and large Backlight display.
- Elapsed time, after starting a measurement, is displayed with the measured values.
- Compact and light weight.
- Test probe with a remote control switch is supplied as standard accessory.
- Auto-discharge with voltage display and the measured value.
- Data transfer and analysis to a PC is possible by using its relative software included in the set.



- Indication of test duration facilitates insulation integrity check with one-minute readings.

PV Insulation 500/1000V	Insulation 250/500/1000V
Earth 20/200/2000Ω	Volts AC 600V/DC 1000V

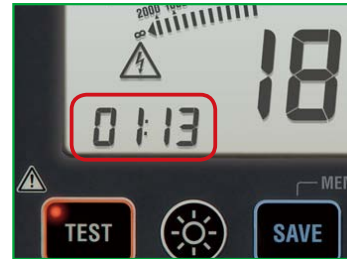

PV INSULATION EARTH TESTER

	6024PV				
Insulation resistance	PV Insulation*		Insulation		
Test voltage	500V	1000V	250V	500V	1000V
Measuring range (Auto range)	20.00/200.0/2000MΩ		20.00/200.0/2000MΩ		
Mid-scale value	-		50MΩ		
Rated current	-		1.0 - 1.2mA		
First effective measuring range	1.51 - 200.0MΩ	1.51 - 1000MΩ	1.51 - 100.0MΩ	1.51 - 200.0MΩ	1.51 - 1000MΩ
Accuracy	±1.5%rdg±5dgt		±1.5%rdg±5dgt		
Second effective measuring range	0.00 - 1.50MΩ	0.00 - 1.50MΩ	1.20 - 1.50MΩ	1.20 - 1.50MΩ	1.20 - 1.50MΩ
Accuracy	±5.0%rdg±6dgt		±5.0%rdg±6dgt		
Open circuit voltage	0 - +20%				
Short circuit current	Max 1.5mA				
Earth resistance					
Measuring range(Auto range)	20.00/200.0/2000Ω				
Accuracy	±3.0%rdg±0.1Ω (20Ω range) ±3.0%rdg±3dgt (200/2000Ω range)				
Voltage measurement					
Measuring range	AC 5 - 600V (45 - 65Hz) DC ±5 - 1000V				
Accuracy	±1.0%rdg±4dgt				
General					
Applicable Standards	IEC 61010-1 CAT IV 300V, CAT III 600V Pollution2 IEC 61010-2-030, IEC 61010-031, IEC 60529(IP54), IEC 61557-1,-2,-5,-10, IEC 61326-1,2-2				
Power source	LR6(AA)(1.5V) × 6				
Dimensions	84(L) × 184(W) × 133(D)mm				
Weight	Approx. 900g (including batteries)				
Accessories	7196A(Test leads with remote control switch), 7244A(Test lead with alligator clip), 8017(Extension prod long), 8072(CAT II Standard prod), 8212-USB(USB adaptor with "KEW Report(Software)"), 9155(shoulder strap), 9156(Carrying case), LR6(AA) × 6, Instruction manual				
Optional	7243(L-shaped probe), 7245A(Precision measurement cord set), 8016(Hook type prod)				

*6024PV supports the PV systems up to 1000V.

PV INSULATION EARTH TESTER

Accurate measurements not influenced by the generating PV voltage

With conventional insulation testers:

[measurement needs to short - circuit the PV arrays]

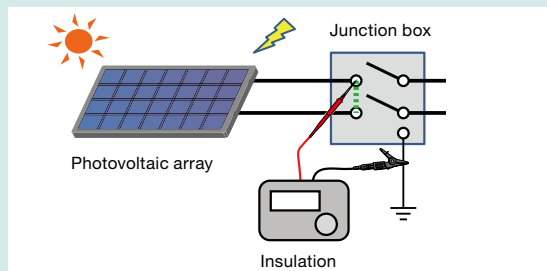

A breaker is required and risk of arc hazard exists.

[measurement without short - circuit the PV arrays]

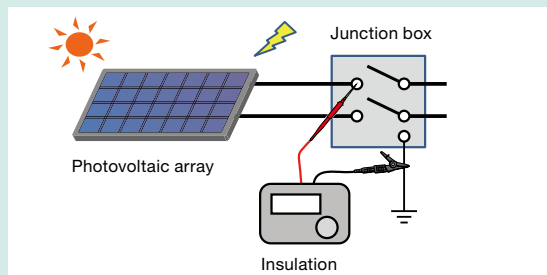

Low-risk, but not accurate.

KEW 6024PV makes safe & accurate insulation resistance measurement possible!

- Increase your efficiency at work: no need waiting for the dark or compromising the accuracy of measurement.
- Safe: no need to short circuit the PV arrays.

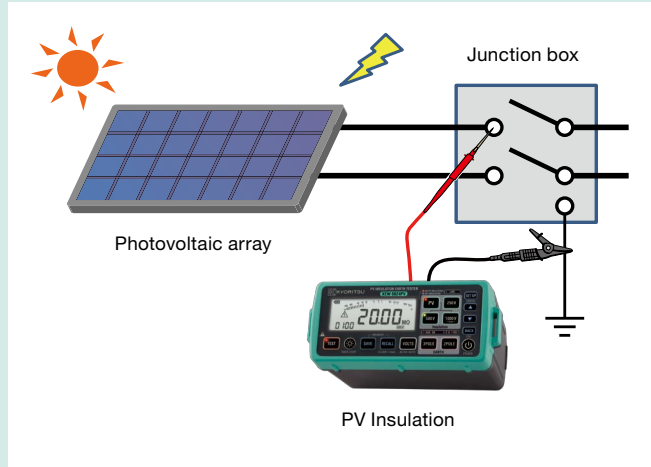

Accurate and quick results also in case of large capacitance effects.

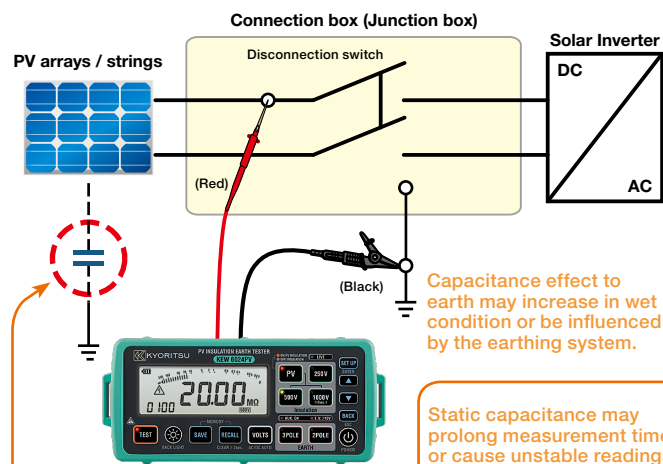

Analyzing and processing the recorded data with a PC.

[Site no.1]
E.g.: Number of the measured connection box

[Data no.]
Number of saved data

[Site no.2]
E.g.: Number of the measured strings



Can measure under the bad weather condition.

Accessories

MODEL 7196A
Test leads with remote control switch

MODEL 7244A
Test lead with alligator clip

MODEL 9156
Soft Case

MODEL 8017
Extension prod long

MODEL 8072
CAT II Standard prod

MODEL 8212-USB
USB adaptor with "KEW Report (Software)"

Optional Accessories

MODEL 7243
L-shaped probe

MODEL 7245A
Precision measurement cord set

MODEL 8016
Hook type prod

POWER QUALITY ANALYZER







POWER METERS



POWER METERS

Selection Guide of Power Meters

	Power Meter	Power Quality Analyzer	Loggers	
	6305	6315	5010	5020
Appearance				
Voltage [V]	✓	✓	✓	✓
Current [A]	✓	✓	✓	✓
Power [W]	✓	✓	-	-
Frequency [Hz]	✓	✓	-	-
Energy [Wh]	✓	✓	-	-
Harmonics	-	✓	-	-
Power Quality	Swell	-	✓	✓
	Dip	-	✓	✓
	Interruption	-	✓	✓
	Transients	-	✓	-
	Inrush Current	-	✓	✓
Memory	SD card	SD card	Inner memory	Inner memory
Number of Input Channel	6ch (V3,A3)	7ch (V3,A4)	3ch	3ch

Power Quality

● Swell

Swell is a instantaneous voltage increase, most of the time originated by upstream power line failure or switching OFF large load or switching ON large capacitor.

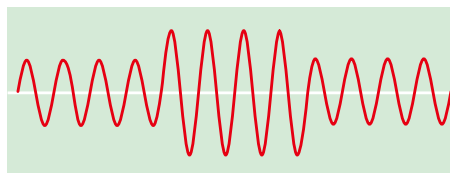

● Dip

Dip, as the opposite of a swell, is a instantaneous voltage decrease, most of the time caused by switching ON large load e.g. motors or by down-stream power line failure.

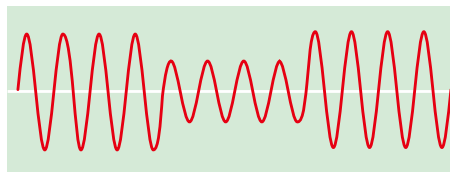

● Interruption

Interruption is a power line cut-off from any source of supply. It can be caused by a fault in a power line, which causes switch gear to open.

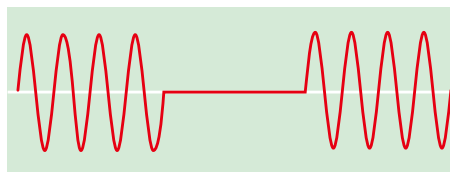

● Transients/Over Voltage (Impulse)

Transient is a very fast and momentary voltage increase that can seriously damage devices connected to a power line. It may be caused by electrical switching events such as instable contacts of relays, tripping of breakers but also by lightning. KEW 6315 can catch Transients from 24 μ s.

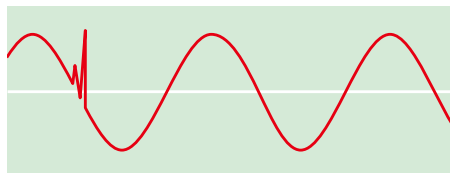

● Inrush Current

Inrush current is a surge current that happens when motors, large or low-impedance loads are switched ON. Then the current will stabilize as soon as the load has reached normal working conditions.

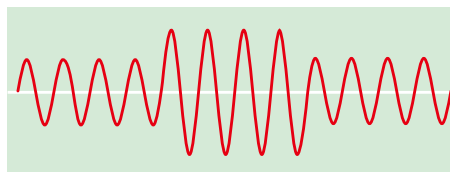

POWER METER

KEW 6305

RMS USB Bluetooth External Power Supply



- Comprehensive real-time monitoring, recording and analysis of single and 3-phase systems
- Voltage, Current, Power Factor and Frequency measurements
- Power analysis (Active, Apparent and Reactive power)
- Energy analysis (Active, Apparent and Reactive energy)
- Active power accuracy: $\pm 0.3\% \text{rdg} \pm 0.2\% \text{f.s.}$
- Automatic wiring check function to prevent incorrect connections
- Large memory capability (2 GB) using built-in SD card Interface
- Recording interval can be set between 1second and 1hour.
- Real time & remote measurements using Android application
- Windows software for data analysis and setting via USB port or Bluetooth

- Synchronous measurements between two units of KEW6305
- Wide selection of clamp sensors allow measurements from 0.1A to 3000A
- The instrument automatically recognizes what kind of clamp sensor is connected to it
- Double power supply system via AC line and batteries

As easy as 1 → 2 → 3!

Starting from OFF position and rotating the Rotary switch clockwise, KEW6305 is ready to use in 3 simple steps

1. SET UP

Rotate the Rotary switch to SET UP. All the instrument settings can be easily selected by using instrument buttons. All the settings can also be selected by connecting KEW6305 to a PC via USB or Bluetooth.

2. WIRING CHECK

Rotate the Rotary switch to WIRING CHECK. The Automatic Wiring check function will prevent incorrect connections, check the connections and display the results on the LCD. Error messages appear on display to indicate wrong orientation of Clamp sensors or incorrect connections.

Everything is OK



Shows "Good"

Error is found



Shows "Err" (Error) e.g.; Err PH A
→ Current phase (orientation of sensor) may be incorrect.

3. W/Wh/DEMAND Measurements

Rotate the Rotary switch to W/Wh/DEMAND. The instrument can perform Instantaneous, Integration and DEMAND measurements. START / STOP button to start / stop recording

	6305
Wiring connections	1P2W, 1P3W, 3P3W, 3P3W3A, 3P4W
Measurements	Voltage, Current, Frequency, Active power
Parameters	Apparent power, Reactive power, Active energy, Apparent energy, Reactive energy, Power factor (cos θ), Neutral current
Voltage range[RMS]	150.0/300.0/600.0V
Voltage accuracy	$\pm 0.2\% \text{rdg} \pm 0.2\% \text{f.s.}$ (sine wave, 45 - 65Hz)
Current range[RMS]	10.00/50.00/100.0/250.0/500.0A/Auto (with clamp sensor MODEL8125)
Current accuracy	$\pm 0.2\% \text{rdg} \pm 0.2\% \text{f.s.}$ + Accuracy of Clamp sensor (sine wave, 45 - 65Hz) *+1% f.s. at the lowest range.
Effective input range	10 - 110% of rating range
Display range	5 - 130% of each range (Voltage) 1 - 130% of each range (Current)
Crest factor	Voltage : up to 2.5, Current : up to 3.0 (with 90% fs or less)
Active power accuracy	$\pm 0.3\% \text{rdg} \pm 0.2\% \text{f.s.}$ + Accuracy of Clamp sensor *+1% f.s. when the lowest current ranges is selected.
Effect of power factor	Active power: $\pm 1.0\% \text{rdg} \cos \theta \pm 0.5$ (PF=1)
Frequency meter range	40.0 - 70.0Hz
Frequency meter accuracy	$\pm 3 \text{dgt}$
Accuracy precondition	PF=1, Sine wave, 45 - 65Hz, 23°C $\pm 5^\circ \text{C}$
Display update period	1 second
Operating temperature and humidity range	0 - +50°C, less than 85% RH (without condensation)
Storage temperature and humidity range	-20 - +60°C, less than 85% RH (without condensation)
PC communication interface	USB, Bluetooth
PC card interface	SD card (2GB)
Safety standard	IEC 61010-1 CAT III 600V
Power supply (AC Line)	AC100 - 240V $\pm 10\%$ (50/60Hz)
Power supply (DC battery)	LR6 or Ni-MH(HR-15-51) $\times 6$ (Battery charger not included), Battery life approx. 15h (LR6)
Power consumption	10VA (max.)
Dimension	175(L) \times 120(W) \times 65(D)mm
Weight	Approx. 800g (including batteries)
Accessories	7141B (Voltage test lead set: 4pcs), 7148 (USB cable), 7170 (Powercord), 9125 (Carrying case), 8326-02 (SD card 2GB), KEW Windows (PC Software), Battery(LR6) $\times 6$, Quick manual
Optional	8124, 8125, 8126, 8127, 8128 (Clamp sensor), 8129, 8130 (Flexible clamp sensor), 8312 (Power supply adaptor), 9132 (Magnetic carrying case)

POWER METER

Bluetooth communication with Android application

Free Android software "KEW Smart 6305" is available on download site



Download



*communication charges may be incurred separately to download application

Real time & remote measurements using Android application

Measurement can be displayed in graphic or numeric forms on Android devices in real-time via Bluetooth communication.

Remote checking of measurements is possible without accessing KEW6305.



Android device

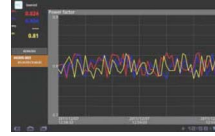

Real-time display

Max communication distance: 10m
Supporting Android ver. 2.2 - 4.4

Bluetooth is a registered trademark of the Bluetooth SIG, Inc.
Android is a registered trademark of the Google Inc.

Windows software

Automatic creation of graph and list from recorded data.
Uniform management of setting and recorded data acquired from multiple devices.

Data can be expressed in crude oil and CO₂ equivalent values in the report.

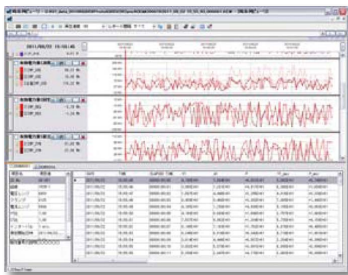

[System requirements]

OS: Windows® Vista/7/8/10
Display: XGA(Resolution 1024x768 dots) or more
Hard-disk: space required 1Gbyte or more
Other: With CD-ROM drive and USB port
.NET Framework (3.5 or more)

* Windows® is a registered trademark of Microsoft in the United States.

SD card Interface

Max amount of data (reference)

Data saved on:	SD card	Internal memory
Capacity	2GB	3MB
Instantaneous measurement	6,670,000	10,000
Integration / demand measurement interval	1 sec.	17 days
	1 min.	992 days
	30 min.	33 hours
Max number of file	511	42 days
		4

*in case the SD card is empty

SD cards up to 2GB can be used.

Set Model

KEW 6305-01

KEW 6305 x 1
MODEL 8125 x 3



Carrying case : 9125

KEW 6305-03

KEW 6305 x 1
MODEL 8130 x 3



Carrying case : 9135

Optional

Load current clamp sensors

MODEL 8128



CE
MAX 50A Ø24

MODEL 8127



CE
MAX 100A Ø24

MODEL 8126



CE
MAX 200A Ø40

MODEL 8125



CE
MAX 500A Ø40

MODEL 8124



CE
MAX 1000A Ø68

Load current flexible clamp sensors

KEW 8129

8129-01 (for 1ch)
8129-02 (for 2ch)
8129-03 (for 3ch)

FLEXIBLE CLAMP SENSOR WITH 3 RANGES
AC300, 1000, 3000A

MAX 3000A Ø150



CE

Power supply adaptor

MODEL 8312

For taking single phase supply (100-240V) from the test leads to power the instrument (FUSE: 8923)



Magnetic carrying case

MODEL 9132

For mounting inside metal distribution boards



KEW 8130

FLEXIBLE CLAMP SENSOR
AC1000A

MAX 1000A Ø110



CE

POWER QUALITY ANALYZER

KEW **6315** **NEW**

True RMS USB Bluetooth External Power Supply



- Simultaneous Power & Power quality measurements
Power/Harmonics/Waveform/Power quality are recorded at all CHs. (Voltage:3ch,Current 4ch)
- Helpful support functions
Quick Start Guide,Wiring check and Sensor detection for easy and reliable measurement
- Measurement with high accuracy
Guaranteed accuracy: $\pm 0.3\%rdg(energy)$,
 $\pm 0.2\%rdg(voltage/current)$
Complies with the International Standard
IEC 61000-4-30 Class S and the European Standard EN50160
- Energy consumption check on site
Trend and demand graphs for easy recognition. TFT color display with high resolution.
- IEC 61010-1 CAT IV 300V,CAT III 600V,CAT II 1000V

		6315
Wiring connections		1P2W, 1P3W, 3P3W, 3P4W
Measurements and parameters		Voltage, Current, Frequency, Active power, Reactive power, Apparent power, Active energy, Reactive energy, Apparent energy, Power factor (cos ϕ), Neutral current, Transients/Over Demand, Harmonics, Quality(Swell/Dip/Interruption, voltage, Inrush current, Unbalance rate), Phase advance condenser, IEC Flicker
Other functions		Digital output function, External communication function,Scaling function
Voltage [RMS]	Range	600.0/1000V
	Accuracy	$\pm 0.2\%rdg \pm 0.2\%f.s.$ (sine wave, 40 - 70Hz)
	Allowable input	1 - 120% of each range (rms). 200% of each range (peak)
	Display range	0.15 - 130% of each range
	Crest factor	3 or less
Current [RMS]	Range	8128(50A type): 5000mA/50.00A/AUTO 8127(100A type): 10.00/100.0A/AUTO 8126(200A type): 20.00/200.0A/AUTO 8125(500A type): 50.00/500.0A/AUTO 8124/8130(1000A type): 100.0/1000A/AUTO 8146/8147/8148(10A type): 1000mA/10.00A/AUTO 8129(3000A type): 300.0/1000/3000A
	Accuracy	$\pm 0.2\%rdg \pm 0.2\%f.s.$ + accuracy of clamp sensor (sine wave, 40 - 70Hz)
	Allowable input	1 - 110% of each range (rms). 200% of each range (peak)
	Display range	0.15 - 130% of each range
	Crest factor	3 or less
Active power	Accuracy	$\pm 0.3\%rdg \pm 0.2\%f.s.$ + accuracy of clamp sensor (power factor 1, sine wave, 40 - 70Hz)
	Influence of power factor	$\pm 1.0\%rdg$ (reading at power factor 0.5 against power factor 1)
Frequency meter range		40 - 70Hz
Power supply (AC Line)		AC100 - 240V/50 - 60Hz/7VA max
Power supply (DC battery)		LR6 or Ni-MH(HR15-51) $\times 6$ Battery life approx. 3h (LR6,Backlight OFF)
Memory card		SD card (2GB)
PC communication interface		USB Ver2.0, Bluetooth Ver2.1+EDR Class2
Display		320 \times 240(RGB)Pixel, 3.5inch color TFT display
Temperature and humidity range		23 \pm 5 $^{\circ}$ C less than 85% RH (without condensation)
Operating temperature and humidity range		0 - 45 $^{\circ}$ C less than 85% RH (without condensation)
Storage temperature and humidity range		-20 - 60 $^{\circ}$ C less than 85% RH (without condensation)
Applicable Standards		IEC 61010-1 CAT IV 300V, CAT III 600V, CAT II 1000V Pollution degree 2, IEC 61010-2-030,IEC 61010-031, IEC 61326,EN50160 IEC 61000-4-30 Class S, IEC 61000-4-15, IEC 61000-4-7
Dimension/Weight		175(L) \times 120(W) \times 68(D) mm/approx 900g
Accessories		7141B(Voltage test lead), 7170(Power cord), 7219(USB cable), 8326-02(SD card 2GB), 9125(Carrying case),Input terminal plate $\times 6$, KEW Windows for KEW6315(software), Quick manual, Alkaline size AA battery(LR6) $\times 6$

Simultaneous Power & Power quality measurements



Power & Energy

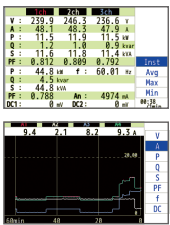

Instantaneous value

- Measures instantaneous / average / min / max for voltage, current, active / reactive / apparent power, PF (cos ϕ) and line frequency all on one screen.
- Trend of all main parameters and customized Zoom functions.

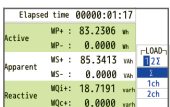

Integration value

- The display will list the active / reactive / apparent energy in total and for each phase consumed (or generated in case of co-generation like solar panels, etc).

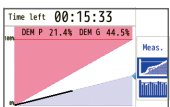

Demand

- To support demand control, present energy usage and estimated value are displayed on a graph while recording max demand value and the occurred time.



Vector

- Can display voltage and current by vector per Ch.

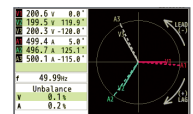

Waveform

- Displays voltage and current on each Ch by waveform.

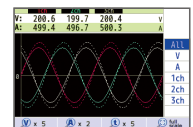

Harmonics Analysis

- Graphic display of harmonic components up to 50th order for voltage, current and power.



Event

- Measures voltage swells / dips / interruptions / transients and inrush currents that may indicate a weak power distribution system. Such phenomena may damage or reset devices. All necessary data is displayed by pressing one key.

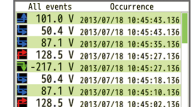

POWER QUALITY ANALYZER

Quick Start Guide

One-Touch START/STOP Key for Quick Start Guide providing easy setup guides.

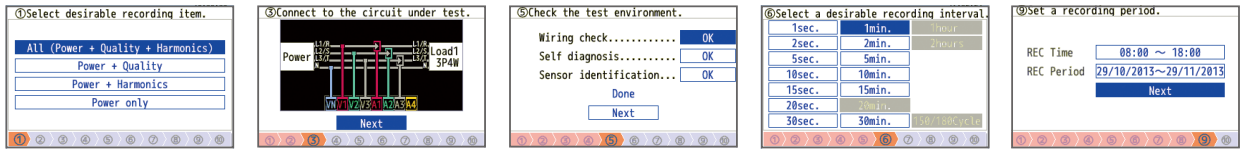

Guide start

Connect to the circuit

Wiring check

Select interval

Set recording time

Start recording

Windows software for data analysis and setting via USB port

- Automatic creation of graph and list from recorded data.
- Uniform management of setting and recorded data acquired from multiple devices.
- Data can be expressed in crude oil and CO₂ equivalent values in the report.
- EN50160 report can be generated after survey.

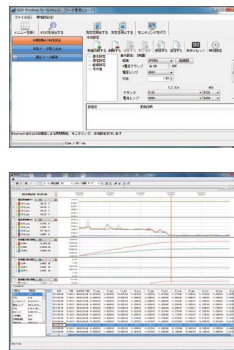

<System requirements>

- OS: Windows®Vista/7/8/10
 - Display: XGA(Resolution 1024×768 dots) or more
 - Hard-disk: Space required 1Gbyteor more
 - Other: With CD-ROM drive and USB port.
NET Framework (3.5 or more)
- *Windows®is registered trademark of Microsoft in the United States.

Real time and Remote measurements

- Measurements can be graphically displayed on Android devices or PC in real-time via Bluetooth communication.



*Bluetooth is a registered trademark of the Bluetooth SIG, Inc.
Android is a registered trademark of the Google Inc.

Optional Accessories

Load current clamp sensors



Leakage & Load current clamp



*8146/8147/8148 can measure up to 10A for use in KEW 6315

Load current flexible clamp sensors



Can you close your distribution board door during surveys?

The KEW6315 facilitates safe testing by being extremely compact and with two clever option extras: a magnetic case(9132) for attaching it to the sides of metal enclosures and a power supply adaptor(8312) which takes the power for the instrument from the supply being measured.



SD card Interface

- SD cards up to 2GB can be used
- Possible recording time
When the 2GB of SD is used:



Interval	REC item	
	Power	+Harmonics
1sec	13days	3days
1min	1-year or more	3months
30min	10-year or more	7-year or more

Data of power quality events are not considered to estimate the possible recording time. The max possible time will be shortened by recording such events.

Set Model



KEW 6315-01
8125(500A) x 3
Carrying case : 9125



KEW 6315-03
8130(1000A) x 3
Carrying case : 9135



LOGGERS

KEW 5010/5020

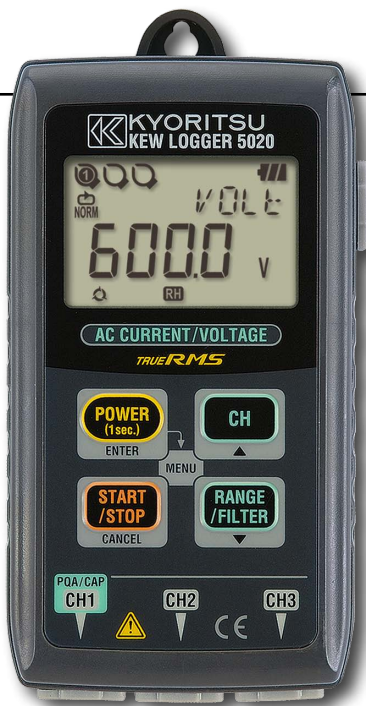

True RMS USB External Power Supply

3 channel inputs for the simultaneous recording of Leakage Current, Load Current and Voltage

Power Quality analysis. (only on KEW 5020)

(Power Quality: Reference voltage, Swell, Dip, Short power Interruptions)

Large capacity for storing 60,000 data points

60,000 data points can be recorded when 1ch is used, and when all the three channels are used, 20,000 data points per channel can be recorded.

Lowpass Filter will filter out the harmonics.

(Cutoff Frequency = Approx. 160Hz)

LED flickers when the preset current / voltage value is exceeded.

(Available for Trigger / Capture Recording, Power Quality Analysis modes)

CALL : Confirmation of recorded data

- The following can be displayed: number of recorded data points, (max+ min+ peak) value for each channel complete with time/date information in the Normal recording mode. (Detected values (i.e. when values are outside preset limits) can be displayed in other recording modes)
- RECALL: The last 10 recorded data points including time/date can be recalled on the logger display.



Selection of One-time mode or Endless mode

One-time on : →

Recording will stop when memory is used up.

One-time off : ↻

Overwrite the old data, and store the latest data.

Non Volatile Memory

Recorded data will be retained even if the batteries are exhausted or replaced due to the presence of a nonvolatile memory (guaranteed for 10 years)

Battery power indicator

Indicates battery voltage in 4-levels.

(It is possible to use the logger for a further approx 24 hours even after the warning symbol is flashing.)

The user friendly PC software " KEW LOG Soft "is supplied.

- Supplied with the user friendly software " KEW LOG Soft 2".
- This permits editing, analysis and graphical display of data.
- The recorded data is downloadable onto a PC via USB cable.
- Variation of the measured voltage and current data can be confirmed simultaneously on the PC display monitor. (only on KEW 5020)
- Simplified Power Integration
(The "KEW LOG Soft 2" uses current and voltage recorded to calculate the integral power consumption)
- Continuous measuring time : Approx. 10 days (Alkaline Battery)

	5010	5020
Recording mode	Normal, Trigger, Capture	Normal, Trigger, Capture, Power quality analysis
Operating system	Successive approximation(CH1 single synchronized sampling)	
Rated max. working voltage	AC9.9Vrms, 14V peak value	
Number of input channel	3ch	
Measuring method	True RMS	
RMS measuring interval	approx. 100ms.	
Sampling interval	: Normal / Trigger mode	approx. 1.65ms/CH
	: Capture mode	approx. 0.55ms (waveform: at every 1.1ms)
	: P.Q.A mode	—
		approx. 0.55ms
Low battery warning	Battery mark display (in 4 levels)	
Over-range indication	"OL" mark is displayed when exceeding the measuring range	
Auto power off	Power-off function operates automatically after a switch remains for 3min. (when recording is stopped)	
Location for use	Indoor use, Altitude up to 2000m	
Operating temperature & humidity range	-10°C - 50°C / Relative humidity 85% or less (no condensation)	
Battery	DC6V : Alkaline battery(LR6) × 4pcs / External supply DC9V(Special AC Adaptor)	
Possible measurement time	Approx.10days (with alkaline LR6 batteries)	
Applicable Standards	IEC 61010-1 CAT III 300V Pollution degree2 IEC 61326 (EMC)	
Dimensions	111(L) × 60(W) × 42(D)mm	
Weight	Approx. 265g	
Accessories	Alkaline battery LR6×4 9118(Carrying case[Soft]) KEW LOG Soft 2(PC software) 7148(USB cable) Instruction manual Quick manual Install manual USB Notice sheet	
Optional	8146/8147/8148(Leakage & Load current clamp sensor) 8121/8122/8123(Load current clamp sensor) 8129(Flexible clamp sensor) 8309(Voltage sensor : only KEW5020) 8320(AC adaptor) 9135(Carrying case) 7185(Extension cable)	

Normal Recording Mode

(AC 50/60Hz, Sine wave, Input: 10% or more of the range at CH1)

Range	RMS Accuracy
100.0mA	±2.0%rdg±0.9%f.s. + Accuracy of sensor
Other ranges	±1.5%rdg±0.7%f.s. + Accuracy of sensor
Crest factor	2.5 or less :RMS accuracy(sine)+ 2%rdg+1%f.s.

*Max, Min and Instant Peak values in Normal Recording mode are just reference values; their accuracies aren't guaranteed.

Trigger Recording Mode

(AC 50/60Hz sine wave)

Range	Accuracy
100.0mA	±3.5%rdg±2.2%f.s. + Accuracy of sensor
Other ranges	±3.0%rdg±2.0%f.s. + Accuracy of sensor

Capture/ Power Quality Analysis Recording Mode

Range	Accuracy
100.0mA	±3.0%rdg±1.7%f.s. + Accuracy of sensor
Other ranges	±2.5%rdg±1.5%f.s. + Accuracy of sensor

Optional Accessories of Loggers, Power Meter and Power Quality Analyzer

Applicable model table

			5010	5020	6305	6315
Sensor	Load current	8121	✓	✓		
		8122	✓	✓		
		8123	✓	✓		
		8124	✓	✓	✓	✓
		8125	✓*1	✓*1	✓	✓
		8126	✓*2	✓*2	✓	✓
		8127	✓*3	✓*3	✓	✓
		8128	✓	✓	✓	✓
		8129	✓*4	✓*5	✓	✓
	8130	✓*4	✓*5	✓	✓	
	Leakage current	8141*6	✓	✓		✓
		8142*6	✓	✓		✓
		8143*6	✓	✓		✓
Leakage & Load current	8146*6	✓	✓		✓	
	8147*6	✓	✓		✓	
	8148*6	✓	✓		✓	
Voltage sensor	8309		✓			
Adaptor	8312			✓	✓	
	8320	✓	✓			
Case	9132			✓	✓	
	9135	✓	✓			

*1 - 5: Can use with after the following serial numbers.

- *1: 8125 No.02637 -
- *2: 8126 No.00151 -
- *3: 8127 No.00181 -
- *4: 5010 No.8029792 -
- *5: 5020 No.8031560 -

*6: Cannot be used for power measurement.

Power supply adaptor

MODEL 8312



Power source can be taken through the measured line (100 - 240v) (FUSE : 8923)

Carrying case with magnet

MODEL 9132



Easy-to-use setting with magnet on the steel plate etc. of switch board

AC adaptor (External power supply)

MODEL 8320



Appropriate for a longer period of recording. Complies to 90 - 264V(45 - 66Hz).

Carrying case

MODEL 9135



Dimensions : 250(L) × 270(W) × 216(D)mm

Voltage sensor

KEW 8309



	8309
Max. input voltage	AC 600Vrms(sin), 848.4Vpeak
Input system	Differential input (can measure floating voltage)
Output voltage	AC 0 - 60mV (output/input : 0.1mV/V)
Measuring ranges	6 - 600V
Accuracy	±1.0%rdg±0.1mV (50/60Hz)
Operating temperature & humidity ranges	-10 to 50°C, less than 85% RH (no condensation)
Input impedance	Approx. 3.4MΩ
Output impedance	Approx. 180Ω
Cable length:	Approx. 2m : MINI DIN 6PIN
Output connector	
Applicable Standards	IEC 61010-1 CAT. III 600V pollution degree 2, IEC 61010-031, IEC 61326 (EMC)
Dimensions/Weight	87(L) × 26(W) × 17(D)mm (excluding protrusions)/135g Approx.
Accessories	Instruction manual
Optional	7185 (Extension cable)
Applicable model	5020

SENSORS

Load current Clamp sensors

KEW 8129

MAX 3000A Ø150

8129-01 (for 1ch)
8129-02 (for 2ch)
8129-03 (for 3ch)

**FLEXIBLE CLAMP SENSOR
CAN MEASURE UP TO
AC3000A HIGH CURRENT**



KEW 8130 **NEW**

MAX 1000A Ø110



	8129-01 (for 1ch)	8129-02 (for 2ch)	8129-03 (for 3ch)	8130
Conductor size	max. ϕ 150mm			max. ϕ 110mm
Rated current	300/1000/3000A			AC 1000A
Output voltage	300A Range :AC500mV/AC300A (1.67mV/A) 1000A Range :AC500mV/AC1000A (0.5mV/A) 3000A Range :AC500mV/AC3000A (0.167mV/A)			AC 500mV/1000A (AC 0.5m V/A)
Accuracy	$\pm 1.0\%$ rdg (45 - 65Hz)			$\pm 0.8\%$ rdg ± 0.2 mV (45Hz - 65Hz) $\pm 1.5\%$ rdg ± 0.4 mV (40Hz - 1kHz)
Phase shift	within $\pm 1^\circ$			within $\pm 2.0^\circ$ (45 - 65Hz)
Cable length Output connector	Sensor part : approx. 2m Output cable : approx. 1m MINI DIN 6PIN			Approx. 3m MINI DIN 6pin
Operating temperature & humidity ranges	0 - 50°C, relative humidity 85% or less (no condensation)			-10 - 50°C, relative humidity 85% or less (no condensation)
Output impedance	100 Ω or less			100 Ω or less
Applicable Standards	IEC 61010-1, IEC 61010-2-032 CAT III 600V Pollution degree2, IEC 61326			IEC 61010-1, IEC 61010-2-030, IEC 61010-2-032 CAT IV 300V /CAT III 600V Pollution degree 2 IEC 61326
Dimensions	111(L) \times 61(W) \times 43(D) mm (except for protrusions)			AMP box 65(L) \times 24(W) \times 22(D)mm(except for protrusions)
Weight	Approx. 410g	Approx. 680g	Approx. 950g	Approx. 180g
Accessories	Instruction manual 7199 (Output cable) \times 1 9137 (Carrying case)	Instruction manual 7199 (Output cable) \times 2 9137 (Carrying case)	Instruction manual 7199 (Output cable) \times 3 9137 (Carrying case)	Instruction manual Cable marker 9095(Carrying case)
Applicable models	5010, 5020, 6305, 6315			

MODEL 8128

MAX 50A Ø24



MODEL 8127

MAX 100A Ø24



MODEL 8126

MAX 200A Ø40



MODEL 8125

MAX 500A Ø40



MODEL 8124

MAX 1000A Ø68



	8128	8127	8126	8125	8124
Conductor size	ϕ 24mm	ϕ 24mm	ϕ 40mm	ϕ 40mm	ϕ 68mm
Rated current	AC 5A (Max.50A)	AC 100A	AC 200A	AC 500A	AC 1000A
Output voltage	AC 50mV/5A [Max. 500mV/50A](AC 10mV/A)	AC 500mV/100A (AC 5mV/A)	AC 500mV/200A (AC 2.5mV/A)	AC 500mV/500A (AC 1mV/A)	AC 500mV/1000A (AC 0.5mV/A)
Accuracy	$\pm 0.5\%$ rdg ± 0.1 mV (50/60Hz) $\pm 1.0\%$ rdg ± 0.2 mV (40Hz - 1kHz)				$\pm 0.5\%$ rdg ± 0.2 mV (50/60Hz) $\pm 1.5\%$ rdg ± 0.4 mV (40Hz - 1kHz)
Phase shift	within $\pm 2.0^\circ$ (45 - 65Hz)		within $\pm 1.0^\circ$ (45 - 65Hz)		
Cable length : Output connector	Approx. 3m : MINI DIN 6pin				
Operating temperature ranges	-0 - 50°C, less than 85% RH (without condensation)				
Output impedance	Approx. 20 Ω	Approx. 10 Ω	Approx. 5 Ω	Approx. 2 Ω	Approx. 1 Ω
Applicable Standards	IEC 61010-1, IEC 61010-2-032 CAT III 300V Pollution degree 2 IEC 61326		IEC 61010-1, IEC 61010-2-032 CAT III 600V Pollution degree 2 IEC 61326		
Dimensions	100(L) \times 60(W) \times 26(D)mm		128(L) \times 81(W) \times 36(D)mm		186(L) \times 129(W) \times 53(D)mm
Weight	Approx. 160g		Approx. 260g		Approx. 510g
Accessories	9095 (Carrying case), Instruction manual, Cable marker				9094 (Carrying case) Instruction manual, cable marker
Optional	7146 (Banana ϕ 4 adjuster plug), 7185 (Extension cable)				
Applicable models	5010, 5020, 6305, 6315				

SENSORS

Leakage & Load current Clamp sensors

KEW **8146**

MAX 30A Ø24



KEW **8147**

MAX 70A Ø40



KEW **8148**

MAX 100A Ø68



	8146	8147	8148
Conductor size	φ24mm	φ40mm	φ68mm
Rated current	AC 30A	AC 70A	AC 100A
Output voltage	AC 1500mV/30A (AC 50mV/A)	AC 3500mV/70A (AC 50mV/A)	AC 5000mV/100A (AC 50mV/A)
Accuracy	0 - 15A ±1.0%rdg±0.1mV (50/60Hz)±2.0%rdg±0.2mV (40Hz - 1kHz) 15 - 30A ±5.0%rdg (50/60Hz),±10.0%rdg (45Hz - 1kHz)	0 - 40A ±1.0%rdg±0.1mV (50/60Hz),±2.0%rdg±0.2mV (40Hz - 1kHz) 40 - 70A ±5.0%rdg (50/60Hz),±10.0%rdg (45Hz - 1kHz)	0 - 80A ±1.0%rdg±0.1mV (50/60Hz),±2.0%rdg±0.2mV (40Hz - 1kHz) 80 - 100A ±5.0%rdg (50/60Hz),±10.0%rdg (45Hz - 1kHz)
Cable length : Output connector	Approx. 2m : MINI DIN 6pin		
Operating temperature ranges	-0 - 50°C, less than 85% RH (without condensation)		
Output impedance	Approx. 90Ω	Approx. 100Ω	Approx. 60Ω
Applicable Standards	IEC 61010-1, IEC 61010-2-032 CAT III 300V Pollution degree 2, IEC 61326		
Dimensions	100(L) × 60(W) × 26(D)mm	128(L) × 81(W) × 36(D)mm	186(L) × 129(W) × 53(D)mm
Weight	Approx. 150g	Approx. 240g	Approx. 510g
Accessories	9095(Carrying case), Instruction manual, Cable marker		9094 (Carrying case), Instruction manual, Cable marker
Optional	7146(Banana φ4 adjuster plug), 7185(Extension cable)		
Applicable models	5010, 5020, 6315(Cannot be used for power measurements.)		

Load current Clamp sensors

KEW **8121**

MAX 100A Ø24



KEW **8122**

MAX 500A Ø40



KEW **8123**

MAX 1000A Ø55



	8121	8122	8123
Conductor size	φ24mm	φ40mm	φ55mm
Rated current	AC 100A	AC 500A	AC 1000A
Output voltage	AC 500mV/100A (AC 5mV/A)	AC 500mV/500A (AC 1mV/A)	AC 500mV/1000A (AC 0.5mV/A)
Accuracy	±2.0%rdg±0.3mV (50/60Hz), ±3.0%rdg±0.5mV (40Hz - 1kHz)		
Cable length : Output connector	Approx. 2m : MINI DIN 6pin		
Operating temperature ranges	-0 - 40°C, less than 85% RH (without condensation)		
Output impedance	Approx. 9.5Ω	Approx. 1.9Ω	Approx. 1.5Ω
Applicable Standards	IEC 61010-1, IEC 61010-2-032, CAT III 300V Pollution degree 2, IEC 61326		
Dimensions	97(L) × 59(W) × 26(D)mm	128(L) × 81(W) × 36(D)mm	170(L) × 105(W) × 48(D)mm
Weight	Approx. 150g	Approx. 260g	Approx. 360g
Accessories	9095(Carrying case), Instruction manual, Cable marker		9094(Carrying case), Instruction manual, Cable marker
Optional	7146(Banana φ4 adjuster plug), 7185(Extension cable)		
Applicable models	5010, 5020		

Leakage current Clamp sensors

KEW **8141**

MAX 1000mA Ø24



KEW **8142**

MAX 1000mA Ø40



KEW **8143**

MAX 1000mA Ø68



	8141	8142	8143
Conductor size	φ24mm	φ40mm	φ68mm
Rated current	AC 1000mA	AC 1000mA	AC 1000mA
Output voltage	AC 100mV/1000mA(AC 100mV/A)		
Accuracy	±1.0%rdg±0.1mV(50/60Hz), ±2.0%rdg±0.1mV (40Hz - 1kHz)		
Cable length : Output connector	Approx. 2m : MINI DIN 6pin		
Operating temperature ranges	-0 - 50°C, less than 85% RH (without condensation)		
Output impedance	Approx. 180Ω	Approx. 200Ω	Approx. 120Ω
Applicable Standards	IEC 61010-1, IEC 61010-2-032, CAT III 300V pollution degree 2, IEC 61326		
Dimensions	100(L) × 60(W) × 26(D) mm	128(L) × 81(W) × 36(D) mm	186(L) × 129(W) × 53(D) mm
Weight	Approx. 150g	Approx. 240g	Approx. 490g
Accessories	9095(Carrying case), Instruction manual		
Optional	7146(Banana φ4 adjuster plug), 7185(Extension cable)		
Applicable models	5010, 5020, 6315(Cannot be used for power measurements.)		



CE

MODEL 5201

DIGITAL ILLUMINOMETER

- Model 5201 is a highly portable and compact digital illuminometer for measuring illuminance from 0.1 to 19,990 Lux, with auto range switching.
- The digital display is held for a preset time (about 20 seconds) and, therefore, facilitates reading, recording and measuring in any direction.

	5201
Ranges	0.1 - 19990Lux(automatic 3 range switching)
Accuracy	±5%rdg±1dgt
Measuring time	2 times per second
Temperature humidity characteristics	±3%(at 20°C)
Angular incident light characteristics	10° Less than ±1.5% 30° Less than ±3% 60° Less than ±10% 80° Less than ±30%
Spectral response characteristics	Closely related to the spectral luminous efficiency (of a standard observer).
Power source	6F22(9V) × 1
Dimensions	166(L) × 68(W) × 32(D)mm
Weight	180g approx.
Accessories	Photocell cover 6F22 × 1 Soft carrying case Instruction manual



CE

MODEL 5202

DIGITAL LIGHT METER

- 3 ranges changeable from low to high illuminance. (200/2000/20000Lux)
- Data hold function.
- Digital light meter with separate light receiving sensor and meter.

	5202		
Ranges	0.1 - 19990Lux		
Accuracy (23°C±5°C)	Lux	Accuracy	
	200	±(4% rdg+5 dgt)	
	2000	±(4% rdg+5 dgt)	
	20000	±(5% rdg+4 dgt)	
Current consumption	2mA approx		
Response time	2.5 times / sec.		
Operating temperature range	0 - 50°C Below 80% RH		
Storage temperature range	-10°C - 60°C		
Angular incident light characteristics	30°Less than ±3%	60°Less than ±10%	80°Less than ±30%
Power source	6F22(9V) × 1		
Dimensions	Meter:148(L) × 71(W) × 36(H)mm Light receiving sensor:85(L) × 67(W) × 32(H)mm		
Weight	270g approx.		
Accessories	Carrying case 6F22(9V) × 1 Photocell cover Instruction manual		

MODEL 5510

Waterproof handheld Infrared Thermometer

- Safe even if getting wet. Dustproof and waterproof structure of IP67.
- Possible to wash
- Please feel secure to use the product on the spot, made from ABS resin of antibacterial specification.
- Shock-proof structure: No damage even if dropped from the height of 1m.
- With auto-power-off function, preventing consumption of the battery
- Wide Temperature Range of -40°C to 300°C
- Small and light: Possible to measure easily by one hand.
- Portable type: Convenient to carry



CE

Relation of Distance and Measuring Diameter

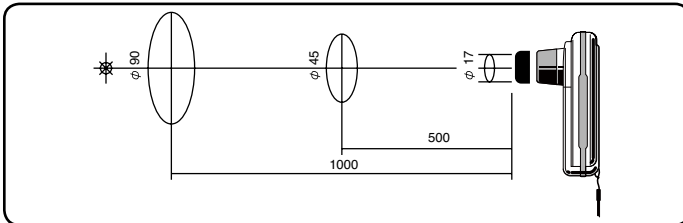

	5510
Measuring range	-40°C - 300°C
Detecting element	Thermopile
Spectral range	6.5μm or more
Display resolution	0.5°C 1°C for below -20°C and over 100°C
Measuring accuracy	When the ambient temperature is 25±2°C and the emissivity (ε) is 1, 0 - 300°C : bigger value of either of ±1% of the measured value ±1dgt or ±2°C ±1dgt. 0 - -30°C : ±3°C ±1dgt below -30°C : ±5°C ±1dgt
Repeatability	within 1°C ±1dgt
Response	1 sec(90% response)
Measuring diameter	φ45mm/500mm(Optical sensitivity: 90%)
Collimation	Before shipment: 0.95. The value can be altered between 0.8 and 1.0 (by 0.05 steps). Laser beam(650nm 1mW JIS class2)specifies the center.
Auto power off	If no key is pressed for 30 seconds, the power is shut off automatically.
Operating temperature	0 - 50°C
Operating humidity	90% rH and below(no condensation)
Storage temperature	-20 - 55°C(no condensation)
Battery	LR03(AAA)(1.5V) × 2
Battery life	Approximately 10 hours for continuous use
Dimensions	120 × 60 × 54mm(Maximum value for each direction)
Weight	123g approx.
Accessories	LR03(AAA) × 2, instruction manual, strap
Approved standard	CE marking:EM1 EN61326 Class B EMS EN61326 Annex C Stability:±5°C under EMC test environment at 25°C

KEW 5711 ^{NEW}

Voltage Detector

CAT IV 600V

- Senses AC voltage through insulation
- Buzzer sounds and tip glows upon ac voltage detection
- Powerful flashlight
- Dual range (Hi/ Lo) sensitivity
- Ready to use without power-on
- Designed to meet IEC61010-1



CE

	5711
Operating voltage	AC 90 - 1000 V(Lo sensitivity) AC 20 - 1000 V(Hi sensitivity)
Frequency range	50/60Hz
Operating temperature	-10 - 50°C
Storage temperature	-20 - 60°C
Applicable Standards	IEC 61010-1 CAT IV 600V / CAT III 1000V Pollution degree 2
Power source	LR03 / R03(AA)(1.5V) × 2
Dimensions	153(L) × φ20mm
Weight	Approx. 40g (including batteries)
Accessories	LR03(AA) × 2, Instruction manual

LED light

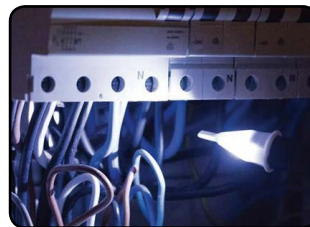

Bright Red Indicator



OTHERS

KEW 8035

Non-Contact Safety Phase Indicator

CAT IV
600V



CE

- New technology permits safe testing, without the need of direct contact between probes and live wires.
- The insulated crocodile clips can clip insulated cables from $\phi 2.4$ to 30mm.
- Phase rotation is indicated by the rotary illumination of LEDs and logical audible tones.
- The instrument can be fixed to a metal panel via the magnet on the back side.
- Wide measuring range for 3 phase installations from 70V to 1000V AC.
- Super brightness function permits clear LEDs indication also in sunshine.

	8035
Functions	Phase rotation (Clockwise or Counter Clockwise), Presence of open phase
Detection method	Electrostatic induction
Measuring voltage range	From 70 - 1000V AC phase to phase (sine wave, continuous input)
Clamp diameter range	From $\phi 2.4$ to 30mm insulated cables
Measuring frequency range	45 to 66Hz
Phase rotation	Clockwise: Green arrow LEDs "rotate" in clockwise, Green symbol "CW" lits, Intermittent buzzer Counter Clockwise: Red arrow LEDs "rotate" in counter clockwise, Red symbol "CCW" lits, continuous buzzer
Visual indication	Via LEDs with Super brightness function
Battery voltage warning	Power LED blinks if battery voltage is too low.
Operating temperature & humidity range	-10 to 50°C, relative humidity 80% or less (no condensation)
Storage temperature & humidity range	-20 to 60°C, relative humidity 80% or less (no condensation)
Applicable Standards	IEC 61010-1 CAT IV 600V, CAT III 1000V Pollution degree 2
Power supply	Alkaline battery (LR6) \times 4 * Continuous use: Approx. 100 hours (Auto power off in about 10 min.)
Dimensions	112(L) \times 61(W) \times 36(D) mm
Weight	380g approx.
Test leads	Double insulated cables, length approx. 70cm
Colours code	L1(U): Red L2(V): White L3(W): Blue
Accessories	9096 (Carrying case), Alkaline battery (LR6) \times 4, Instruction manual

MODEL 8030

DIGITAL PHASE INDICATOR with open phase checker

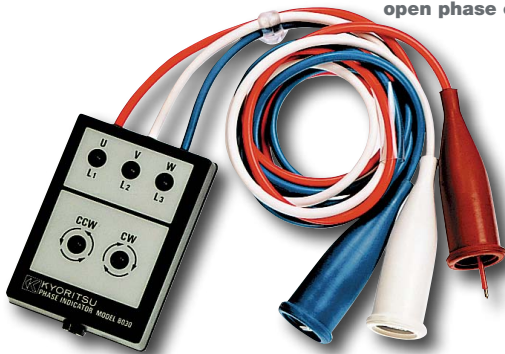

	8030
Operational voltage	200 - 480V AC
Time limit for continuous	200V : within 60 minutes 480V : within 4 minutes
Frequency response	20 - 400Hz
Dimensions	82(L) \times 59(W) \times 23(D)mm
Weight	200g approx.
Cord	1m(R: red S: white T: blue)
Accessories	9070(Carrying case) Pins for test leads Instruction manual

- Phase indicator designed to check the presence of open phase and also the phase sequence by LED and buzzer at the same time.
- Small, lightweight, and portable.

MODEL 8031 / KEW 8031F

PHASE INDICATOR with open phase checker

PHASE INDICATOR with fused test leads



CE

photo : 8031F

- Phase indicator designed to check the presence of open phase and also the phase sequence by rotating disk and lamps.
- Can check a wide range of 3-phase power source from 110V to 600V. Sealed against dust, the unit ensures trouble-free performance.
- Small, Lightweight and portable. Designed for maximum ease of operation and ruggedness.
- No exposed metal parts, Safety features are incorporated including the instant push button switch operation.(8031F Only)

	8031		8031F
	CE Type	Standard Type	
Operational voltage	110 - 600V AC		
Fuse	—		0.5A/600V (F)
Time limit for continuous	>500V : within 5 minutes		
Frequency response	50/60Hz		
Applicable Standards	IEC 61010-1 CAT III 600V Pollution degree 2	—	IEC 61010-1 CAT III 600V Pollution degree 2
Dimensions	106(L) \times 75(W) \times 40(D)mm		
Weight	350g approx.		
Cord	1.5m(R: red S: white T: blue)		
Accessories	9029(Carrying case) Instruction manual		9094(Carrying case) Instruction manual



MODEL 8031
CE type

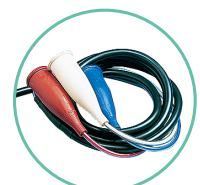

MODEL 8031
Standard type



KT 200

AC CLAMP METER

Ø30 MAX 400A AC A DC AC V Ω ●●)

DATA HOLD AUTO POWER SAVE

- Small and handy clamp meter
- IEC 61010-1 Safety Standard CAT III 300V, CAT II 600V
- 400A AC Clamp meter
- DMM function ACV, DCV, Ω Continuity Buzzer.

KT 200	
AC A	40.00/400.0A ±2.0%rdg±6dgt(50/60Hz)
AC V	400.0/600V(Auto-ranging) ±2.0%rdg±5dgt(50/60Hz)
DC V	400.0/600V(Auto-ranging) ±1.5%rdg±5dgt
Ω	400.0/4000Ω(Auto-ranging) ±2.0%rdg±5dgt
Continuity buzzer	buzzer sounds below 50±35Ω
Conductor size	φ30mm max.
Applicable Standards	IEC 61010-1 CAT III 300V(ACA), CAT II 600V Pollution degree 2 IEC 61010-2-032, IEC 61326-1
Power source	R03(1.5V)(AAA) × 2 *Continuous measuring time: approx. 200 hours (Auto power save: approx. 10 minutes)
Dimensions	184(L) × 68.6(W) × 38.5(D)mm
Weight	Approx. 190g (including batteries)
Accessories	7066A (Test leads), R03(AAA) × 2, Instruction manual
Optional	9105 (Carrying case)

CE



KT 203

AC/DC CLAMP METER

Ø30 MAX 400A DC AC A DC AC V Ω ●●)

DATA HOLD AUTO POWER SAVE

- Small and handy clamp meter
- IEC 61010-1 Safety Standard CAT III 300V, CAT II 600V
- 400A AC/DC Clamp meter
- DMM function ACV, DCV, Ω Continuity Buzzer.

KT 203	
AC A	40.00/400.0A (Auto-ranging) ±3.0%rdg±8dgt[50/60Hz](0 - 40.00A) ±3.5%rdg±6dgt[50/60Hz](15.0 - 299.9A) ±4.0%rdg±6dgt[50/60Hz](300.0 - 400.0A)
DC A	40.00/400.0A (Auto-ranging) ±3.0%rdg±8dgt (0 - 40.00A) ±3.5%rdg±6dgt (15.0 - 299.9A) ±4.0%rdg±6dgt (300.0 - 400.0A)
AC V	400.0/600V(Auto-ranging) ±2.0%rdg±5dgt(50/60Hz)
DC V	400.0/600V(Auto-ranging) ±1.5%rdg±5dgt
Ω	400.0/4000Ω(Auto-ranging) ±2.0%rdg±5dgt
Continuity buzzer	buzzer sounds below 50±35Ω
Conductor size	φ30mm max.
Applicable Standards	IEC 61010-1 CAT III 300V(ACA), CAT II 600V Pollution degree 2 IEC 61010-2-032, IEC 61326-1
Power source	R03(1.5V)(AAA) × 2 *Continuous measuring time: approx. 35 hours (Auto power save: approx. 10 minutes)
Dimensions	187(L) × 68.5(W) × 38.5(D)mm
Weight	Approx. 200g (including batteries)
Accessories	7066A (Test leads), R03(AAA) × 2, Instruction manual
Optional	9105 (Carrying case)

CE

KT 170/171

VOLTAGE TESTER

CAT IV
600V



CE

CE

photo : KT170

photo : KT171

Probe Protection Cover



KT170/171	
Voltage test	
Voltage range	12 - 690V AC/DC
LED	
Nominal voltage	12/24/50/120/230/400/690V AC(16 - 400Hz), DC(±)
Tolerance (Threshold voltage)	Light on at more than: 7±3V (12V LED) 18±3V (24V LED) 37.5±4V (50V LED) 75%±5% of nominal voltage (120/230/400/690V LED)
Response time	< 0.6s at 100% of each nominal voltage
LCD (KT171 only)	
Range / Resolution (Auto-range)	300V AC/DC (6.0 - 299.9) / 0.1V 690V AC (270 - 759) / 1V 690V DC (270 - 710) / 1V
Accuracy (23±5°C)	±1.5V (7 - 100V) ±1%±5dgt (100 - 690V) AC(16 - 400Hz), DC(±)
Over limit indication	"OL"
Response time	Approx. 1s at 90% - 100% of each voltage
Peak current	Is<3.5mA (at 690V)
Measurement Duty	30s ON (operation time) 240s OFF (recovery time)
Single-pole phase test	
Voltage range	100 - 690V AC (50/60Hz)
Phase rotation test	
System	Three-phase 4-wire system 200 - 690V phase-to-phase AC (50/60Hz)
Phase range	120±5 degree
Continuity test	
Detection range	0 - 400kΩ + 50%
Test current	Approx. 1.5μA (battery 3V, 0Ω)
Operating temperature and humidity ranges	-15 - 55°C, max 85% RH (No condensation)
Storage temperature and humidity ranges	-20 - 70°C, max 85% RH (No condensation)(KT170) -20 - 60°C, max 85% RH (No condensation)(KT171)
Applicable Standards	IEC 61243-3, IEC 61010-1, IEC 61010-031, IEC 61557-7 CAT IV 600V / CAT III 690V Pollution degree 2, IEC 60529 (IP65)
Power source	LR03(AAA) (1.5V) × 2
Dimensions	246(L) × 64(W) × 26(D)mm
Weight	195g (including batteries)
Accessories	LR03(AAA) × 2, KTA01(4mm metal tips[2pcs/set]), KTA02(4mm rubber caps[2pcs/set]), Instruction manual

KT170AU is available for Australia and New Zealand market.

- Comply with the latest standards IEC 61243 and IEC 61010
- Novel design
Large and bright LEDs: Values are visible in the dark place.
Ergonomic design fits in the hand.
- Two functions are available in one model.
"Measurement without battery" and "Self Test (all LED on)"
- Test leads withstand harsh environments at low temperature.
- Penlight(white LED)
- Auto-power ON / OFF
- Audible indication
- Variable test tips, φ2mm or φ4mm
- Probe protection cover can store the attachment of caps.
- IP65 (IEC 60529)

Variable top tips

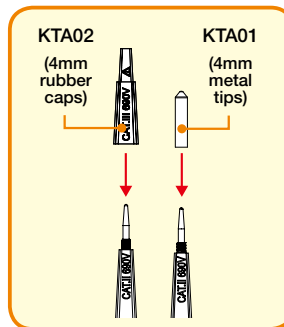

Store the attachment of caps

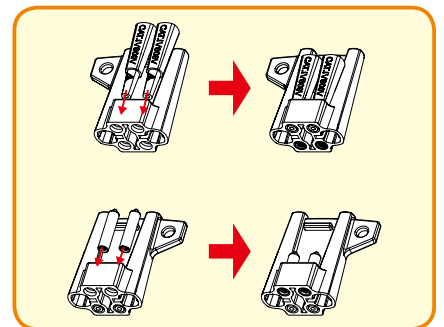

Voltage Test (Double-pole Test)

- The voltage is indicated by LEDs.
- Buzzer sounds and Live circuit LED lights up when a threshold voltage of 50V is exceeded.
- Voltage polarity is indicated in following manner.

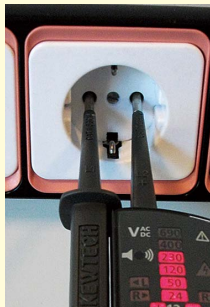

AC +DC -DC
+12 - +12 - +12 -

Bright LEDs and Penlight



Single-pole Phase Test

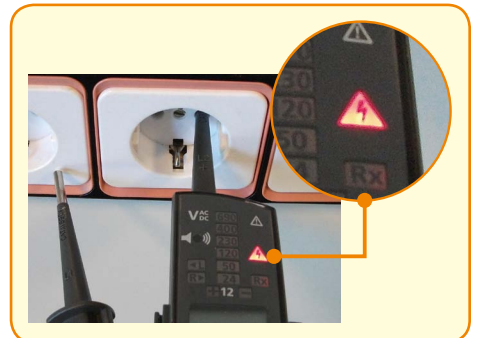

ACCESSORIES

7025

1,500mm

Applicable model
3165
3166



7066A

1,100mm

Applicable model
1009 2046R
1011 2055
1012 2056R
1020R 2117R
1021R 2127R
1109S 2608A
1110 KT200
2007R KT203



7073

2,120mm

*2WAY Output cord

Applicable model
2413F
2413R



7082

1,100mm

*Lead for recorder

Applicable model
3124



7083

5,200mm

*Lead for battery charging

Applicable model
3124



7084

5,000mm

*Earth and guard leads

Applicable model
3124



7095A

*Earth resistance test leads

Applicable model
4102A
4105A
6018



Green: 5m
Yellow: 10m
Red: 20m

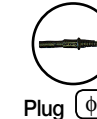

7100A

Applicable model
4102A
4105A
6018



Consists of :
7095A(Earth resistance test leads)
8032(Auxiliary earth spikes)
8200-03(Cord reels [3pcs])
9091(Carrying case for cord reels)

Green: 5m
Yellow: 10m
Red: 20m



7103A/7139A

Line 1,000mm Earth 1,550mm

*Test leads with remote control switch

Applicable model

7103A **7139A**
3021 3023 3161A
3022 6018

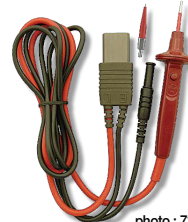
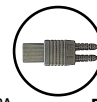

photo : 7103A



7107A

1,100mm

Applicable model
2002PA
2002R
2003A
2009R
2200
2200R



7115/7116

1,000mm

*Extension probe

Applicable model

7115 **7116**
3021 3023 3161A
3022 6018

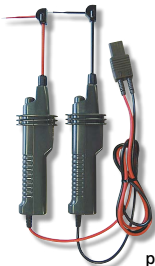
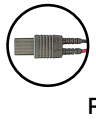

photo : 7115



7121B

1,500mm

*Distribution board test leads

Applicable model

4118A
5406A
6201A



7122B

1,220mm

Applicable model
3005A 6010B
3007A 6011A
3131A
3132A



7123/7124/7125/7126

1,500mm

*Molded plug test lead

Applicable model

4118A
5406A

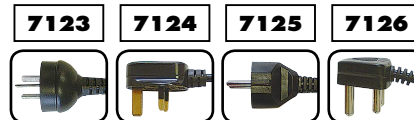

7123 (AU)
6201A

Plug

7123 : (AU) Australian plug
7124 : (UK) British plug (13A)
7125 : (EU) European SHUKO plug
7126 : (SA) South african plug

photo : 7123

ACCESSORIES

7127A 1,570mm

*Simplified measurement probe

Applicable model
4102A
4105A



7127B 1,570mm

*Simplified measurement probe

Applicable model
4105DL

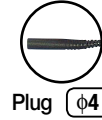

7128A 1,390mm

Applicable model
5410



7129A 1,450mm

Applicable model
5410
6201A

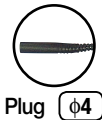

7132A 1,200mm (KSLP5)

Applicable model
6011A



7133B 1,500mm (OMA DIEC)

Applicable model
6010B
6011A



7141B 3,000mm

*Voltage test lead set

Applicable model
6305
6315



7146 190mm

*Banana $\phi 4$ adjuster plug

Applicable model
8121 8128
8122 8141
8123 8142
8124 8143
8125 8146
8126 8147
8127 8148



7149A/7150A Line 1,000mm Earth 1,550mm

*Test leads with remote control switch set

Applicable model

7149A 7150A
3161A 3021 3023
3022



7153B 1,220mm

*Safety test leads

Applicable model
1009 2007R
1011 2046R
1012 2055
1020R 2056R
1021R 2117R
1109S 2127R
1110 2608A



7154B 1,220mm

*Safety test leads

Applicable model
1009 2056R
1011 2117R
1012 2127R
1020R 2608A
1021R 3165
1109S 3166
1110 6010B
2007R 6011A
2046R 6016
2055



7155B

*Safety test leads with fuse

Applicable model
7153B
7154B



7156B 1,220mm

*Safety test leads with fuse

Applicable model
1009 2056R
1011 2117R
1012 2127R
1020R 2608A
1021R 3165
1109S 3166
1110 6010B
2007R 6011A
2046R 6016
2055



7157B/7158B

Applicable model
7153B 7154B

Applicable model
7155B 7156B



7157B



7158B

7159B 1,220mm

*Safety test leads with fuse

Applicable model
1009 2056R
1011 2117R
1012 2127R
1020R 2608A
1021R 3165
1109S 3166
1110 6010B
2007R 6011A
2046R 6016
2055



ACCESSORIES

7165A 3,000mm

*Line probe



Applicable model

3025A
3121B
3122B
3123A
3125A
3127

7168A 3,000mm

*Line probe with alligator clip



Applicable model

3025A
3121B
3122B
3123A
3125A
3127

7170 2,000mm

*Power cord



Applicable model

3128
6305
6315

7185 3,000mm

*Extension cable



Applicable model

5010 8128
5020 8141
8121 8142
8122 8143
8123 8146
8124 8147
8125 8148
8126
8127

7187A/7218A/7221A/7222A 1,230mm

*Main test lead



photo : 7218A

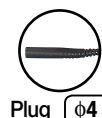

Plug $\phi 4$

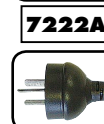
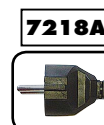
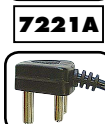
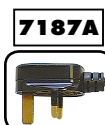

Applicable model

4140
6016

7187A : UK plug
7218A : EU plug
7221A : SA plug
7222A : AU plug

Plug

7188A 1,520mm

*Distribution board fused test leads



Applicable model

6016



Plug $\phi 4$

7196A 1,550mm

*Test leads with remote control switch



Applicable model

6016
6024PV

7199 1,000mm

*Output cable



Applicable model

8129

7219 1,950mm

*USB cable



Applicable model

6315

7220A 1,080mm

*Applicable model

1051
1052
1061
1062



Plug $\phi 4$

7224A 1,500mm

*Earth cord



Applicable model

3123A
3127
3128

7225A 1,500mm

*Guard cord



Applicable model

3123A
3127
3128

7226A 3,000mm

*Line probe



Applicable model

3128

7227A 3,000mm

*Line probe with alligator clip



Applicable model

3128

ACCESSORIES

7228A

*Earth resistance test leads



Applicable model
6016

Green : 5m
Yellow : 10m
Red : 20m



7229A

*Earth resistance test leads



Applicable model
4106

Green : 20m
Yellow : 20m
Black : 20m
Red : 40m



7234 1,080mm

*Alligator clip



Applicable model

1009 1051
1011 1052
1012 1061
1020R 1062
1021R



7238A 1,570mm

*Simplified measurement test leads



Applicable model
4106



7243 1,650mm

*L-shaped probe



Applicable model
3431
6024PV

7244A 1,400mm



Applicable model
6024PV

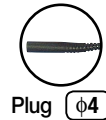

7245A



Consists of :
7228A(Earth resistance test leads)
8032(Auxiliary earth spikes(2 spikes/set))
8200-03(Cord reels(3 pcs))
9142(Carrying bag)

Applicable model
6024PV

Green : 5m
Yellow : 10m
Red : 20m

7246/7247 1,400mm

*Distribution board test lead



Applicable model
4140

7246
Blue, Green, Red

7247
Black, Green, Red



7248 2,000mm



Applicable model
4300



7253/7254 15m

*Longer line probe with alligator clip



photo : 7253

Applicable model
7253

3121B 3025A
3122B 3125A
3123A 3127

7254
3128

7256 1,200mm

*Out put cord



Applicable model

2002PA 2010
2002R 2500
2003A 2510
2009R



7260 1,400mm

*Test leads with remote control switch



Applicable model
3431

7261 1,400mm



Applicable model
3431



7264 3,000mm

*Earth cord



Applicable model

3025A
3121B
3122B
3125A

7265 3,000mm

*Guard cord



Applicable model

3025A
3121B
3122B
3125A

ACCESSORIES

7266

*Earth resistance test leads



Applicable model
4105DL

Green: 5m
Yellow: 10m
Red: 20m



Plug $\phi 4$

7267 20m

*Cable reel for Earth resistance tester (Red)



Applicable model
4105DL

7268 10m

*Cable reel for Earth resistance tester (Yellow)



Applicable model
4105DL

7269 20m

*Earth resistance test lead (Red)



Applicable model
4105DL



Plug $\phi 4$

7270 10m

*Earth resistance test lead (Yellow)



Applicable model
4105DL



Plug $\phi 4$

7271 5m

*Earth resistance test lead (Green)



Applicable model
4105DL



Plug $\phi 4$

7272

*Precision measurement Cord set



Applicable model
4105DL

Consists of:
7267(Cable reel for Earth resistance tester (Red))
7268(Cable reel for Earth resistance tester (Yellow))
7271(Earth resistance test lead (Green))
8041(Auxiliary earth spikes[2 spikes/1set])
9192(Carrying case for cord reels)

Green: 5m
Yellow: 10m
Red: 20m

8216 1,000mm

*Temperature probe



Applicable model
1011
2046R
2056R

8405 1,400mm

*Temperature probe



Applicable model
1051 1061
1052 1062

• -40°C - 500°C, Surface type,
Point material: Ceramic



Plug $\phi 4$

8406 1,380mm

*Temperature probe



• -40°C - 500°C, Surface type



Plug $\phi 4$

8407 1,540mm

*Temperature probe



• -40°C - 700°C, Liquid,
Semi-solid



Plug $\phi 4$

8408 1,540mm

*Temperature probe



• -40°C - 600°C, Air, Gas



Plug $\phi 4$

KAMP10 1,500mm

*Test lead with IEC connector

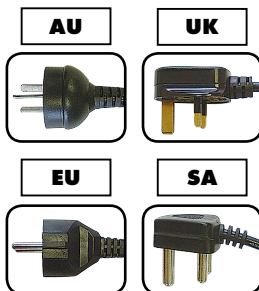

Plug

Applicable model
6010B
6011A

AU : Australian plug
UK : British plug (13A)
EU : European SHUKO plug
SA : South african plug

ACCESSORIES

8901

Fuse [0.5A/250V]

Applicable model
1109S



8918

Ceramic fuse [0.8A/600V]

Applicable model
1011
1012



8919

Ceramic fuse [10A/600V]

Applicable model
1009
1011
1012
1021R



8923

Fuse [0.5A/600V]

Applicable model
1009
1110
2608A
3005A
3007A
3021
3022
3023
3131A
3132A
8312



8926

Fuse [440mA/1000V]

Applicable model
1051
1052
1061
1062



8927

Fuse [10A/1000V]

Applicable model
1051
1052
1061
1062



Accuracy

The accuracy of a digital tester is defined as the difference between the reading and the true value for a quantity measured in reference conditions. Accuracy is specified in the format: ($\pm xx\%$ rdg $\pm xx$ dgt)

The first portion identifies a percentage error relative to the reading, which means it is proportional to the input. The second portion is an error, in digits, that is constant regardless of the input.

"Rdg" is for reading and "dgt" is for digits. Dgt indicates the counts on the last significant digit of the digital display and is typically used to represent an error factor of a digital tester.

Auto-discharge Function

A function used immediately after an insulation test to automatically release charges stored within the circuit under test during measurement.

Voltage remaining in the circuit under test can be monitored during auto-discharging process as the scale reading.

Auto-ranging

A function of a tester to automatically select the appropriate measuring range based on the input signal.

Average Value

The average of an AC waveform's instantaneous values taken over a half cycle. Ordinary testers respond to the average value.

For sinusoidal wave :

Average value = Maximum value $\times 2/\pi$ = Maximum value $\times 0.637$

When the true RMS value is 100V ;

Average value = Maximum value $\times 2/\pi$ = $141 \times 0.637 = 90(V)$

The reading of ordinary testers is calibrated in terms of the effective value of a sinusoidal wave even though they are responding to the average value. They are called average-responding-RMS-calibrated type of testers. As opposed to these, true-RMS type testers respond and show the true RMS value.

Crest Factor

The ratio of the maximum value to the effective value.

It represents the range of input in which a tester maintains linear operation, expressed by a multiple of the full scale value of the range being used.

Crest factor = Maximum value / True RMS value

For sinusoidal wave;

Crest factor = $141/100 = 1.41$

Data Hold

A function to freeze the reading on a digital display for ease of checking or recording even in a difficult-to-read situation for a tester.

Decibel: dB

A unit used to express the magnitude of change in level of electric signal or sound intensity.

A voltage ratio of 1 to 10 is equal to -20dB, 10 to 1 to 20dB, 100 to 1 to 40dB and 1000 to 1 to 60dB. A power ratio of 10 to 1 is not 20dB, but 10dB, since power(P) is proportional to the square of voltage(V).

Diode Test

A function to apply a diode or a transistor a constant current having a value needed to turn it on in order to check the diode's or the transistor's forward voltage drop and identifying the connection direction of the device.

Distortion Factor

A degree of distortion of a waveform, typically expressed as the ratio of the effective value of harmonic components to the effective value of the fundamental component.

Dual Integration Method

A technique to convert voltage into time. The first integration time (Ts) and the second integration time (Tx) are used. First, the input voltage (Vx) is integrated on a certain time interval (Ts) and then, the resulting voltage is "reverse-integrated" using a reference voltage (Vr) until it becomes 0 (zero).

The "reverse-integration time" (Tx) is proportional to input voltage (Vx). Therefore, the input voltage (Vx) can be determined by measuring Tx.

With this technique, stable measurements can be taken with high accuracy, resolution and noise rejection ratio. One particular advantage is high noise rejection ratio at 50 or 60Hz power line frequency. All of Kyoritsu digital clamp meters and testers utilize this method.

Effective Measuring Range of Insulation Tester

The measuring range for which the accuracy of an insulation tester is guaranteed. There are two kinds of effective measuring ranges: the first and second effective measuring ranges.

First effective measuring range

From 1/1000 to 1/2 the maximum effective scale value (When there is no major scale division for 1/2 the maximum effective scale value, the nearest major scale division is used.)

Second effective measuring range

Scales divisions not included in the first effective measuring range

For example for a 500V/100M Ω insulation tester;

First effective measuring range: 0.1-50M Ω ($\pm 5\%$ of indicated value)

Second effective measuring range: 50-100M Ω ($\pm 10\%$ of indicated value)

Form Factor

The ratio of the effective value to the average value.

Form factor = Effective value / Average value

Frequency Response

The manner in which a device changes its output quantity it, its indication for a measured quantity or its response over a range of frequencies.

AC signals to measure with a tester can be of one frequency or from a wide frequency band ranging from low to high frequencies. To measure these frequencies, it is better to use a tester having a wide frequency response range.

Hall Element

When a current-carrying conductor is placed in a magnetic field so that the direction of the magnetic field is perpendicular

GLOSSARY

to the direction of the current flow, voltage is developed in the direction perpendicular to both the magnetic field and the current flow. This is called the Hall effect and the Hall element is a device that utilizes the effect. Kyoritsu AC/DC clamp meters and clamp sensors employ the Hall element.

Harmonics

Power line AC voltage from a utility company has near sinusoidal waveform of fundamental frequency with little distortion. When only a load consisting of resistors, capacitors and coils, called a linear load (its constant is fixed regardless of the amount of current flowing through it), is connected to mains supply, no distortion is introduced into the load current waveform. However, when a non-linear load, such as a semiconductor and a saturable reactor, is connected, distortion appears in the load current waveform. The current with a waveform containing distortion, or harmonic current, flows in the direction toward the low impedance side and in the process, produces voltage drop over the impedance of the current path, causing the load voltage also to contain harmonics.

Indicated Value

The value indicated by a tester for a measured quantity

Peak Hold

A function to memorize the peak value over a certain period of time.

*Response time is selectable from approx. 10ms and 100ms. Reading in the peak hold mode is the peak current value multiplied by $1/\sqrt{2}$. (When the input is sinusoidal, the reading is equal to the true RMS value.)

Peak Value

The value at a point where a waveform has the maximum amplitude.

Resolution

The minimum increments in which a tester can take measurements.

Sample Rate

Frequency at which an A/D converter circuit senses the quantity to measure: typically, twice or three times per second.

Sensitivity

The ability of a tester to respond to the quantity to measure, expressed as the ratio of a change induced in the reading to a change in the input:

$$\text{Sensitivity} = \frac{\text{Change in reading}}{\text{Change in quantity to measure}}$$

Shock Hazard

Also referred to as electric shock. When a person touches a motor that has a "leak", a path can be created from the motor frame to the hand, body and feet of the person to the floor he is standing on to allow a current to flow through it, sometimes resulting in a fatal accident.

The seriousness of a shock hazard widely varies depending on the amount and duration of the current that flows through the person's body. His constitution, age and medical condition are also variation factors, but in general, at a frequency of 50 or 60Hz, stimulus to the skin is felt at 1mA, considerable pain occurs at 5mA, pain is unbearable at 10mA, there is difficulty in releasing the "leaking" object because of intense muscle contraction at 20mA, it is considerably dangerous at 50mA and fatality is likely at 100mA. For the safety limit for a fatal current, which causes ventricular fibrillation, Professor Dalziel proposed the following equation from numbers of experiments on animals.

$$I = 165 \sqrt{t}$$

Where, I = current (mA) and t = time (sec).

From this theory, the maximum duration for a current of 165mA is 1 second.

Thermocouple

A device that uses the voltage developed by the junction of two dissimilar metals to measure temperature. One junction, called the measuring junction, is placed at the point where temperature is to be measured. The other junction, called the reference junction, is maintained at a reference temperature. The voltage developed between the two junctions varies depending on the difference between the temperatures of the two junctions and the type of thermocouple.

True RMS Value

The square root of the average of the square of a periodic waveform's instantaneous values taken over one cycle. It is also called the rms value and the most closely relates to such form of energy as force and heat.

(The effective value of an alternating current is expressed as the value of the direct current which produces the same amount of heat as the alternation current does.)

For sinusoidal wave :

$$\text{True RMS} = \text{Maximum value} \times 1/\sqrt{2} = \text{Maximum value} \times 0.707$$

When a True RMS is 100V ;

$$\text{Maximum value} = \text{True RMS} \times \sqrt{2} = 100 \times 1.41 = 141(\text{V})$$

Measurement categories (Over-voltage categories)

To ensure safe operation of measuring instruments, IEC 61010 establishes safety standards for various electrical environments, categorized as O to CAT IV, and called measurement categories. Higher-numbered categories correspond to electrical environments with greater momentary energy, so a measuring instrument designed for CAT III environments can endure greater momentary energy than one designed for CAT II.

O : Circuits which are not directly connected to the mains power supply.

CAT II : Electrical circuits of equipment connected to an AC electrical outlet by a power cord.

CAT III : Primary electrical circuits of the equipment connected directly to the distribution panel, and feeders from the distribution panel to outlets.

CAT IV : The circuit from the service drop to the service entrance, and to the power meter and primary overcurrent protection device (distribution panel).

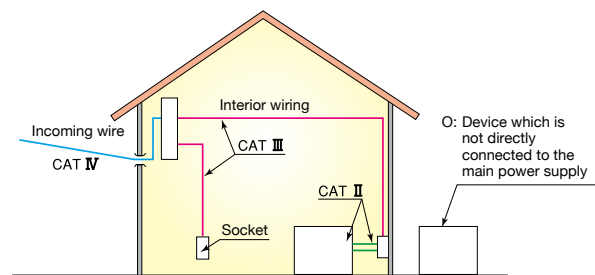

PRODUCT INDEX

1000		
1009	Digital Multimeter	11
1011	Digital Multimeter	11
1012	Digital Multimeter	11
1018	Digital Multimeter (Soft case type)	12
1018H	Digital Multimeter (Hard case type)	12
1019R	Digital Multimeter	12
1020R	Digital Multimeter	10
1021R	Digital Multimeter	10
1030	Digital Multimeter (Pen type)	12
1051	Digital Multimeter	14
1052	Digital Multimeter	14
1061	Digital Multimeter	14
1062	Digital Multimeter	14
1109S	Analogue Multimeter	11
1110	Analogue Multimeter	11

2000		
2000	Digital Multimeter	13
2001	Digital Multimeter	13
2002PA	Digital Clamp Meter	19
2002R	Digital Clamp Meter	19
2003A	Digital Clamp Meter	22
2007R	Digital Clamp Meter	19
2009R	Digital Clamp Meter	22
2010	Digital Clamp Meter	22
2012R	Digital Multimeter	13
2031	Digital Clamp Meter	20
2033	Digital Clamp Meter	23
2046R	Digital Clamp Meter	23
2055	Digital Clamp Meter	23
2056R	Digital Clamp Meter	23
2117R	Digital Clamp Meter	20
2127R	Digital Clamp Meter	20
2200	Digital Clamp Meter	21
2200R	Digital Clamp Meter	21
2204R	Digital Clamp Meter	21
2210R	Digital Clamp Meter	21
2300R	Fork Current Tester	26
2413F	Leakage Clamp Meter	26
2413R	Leakage Clamp Meter	26
2431	Leakage Clamp Meter	25
2432	Leakage Clamp Meter	25
2433	Leakage Clamp Meter	25
2433R	Leakage Clamp Meter	25
2434	Leakage Clamp Meter	26
2500	DC Milliamp Clamp Meter	24
2510	DC Milliamp Clamp Logger	24
2608A	Analogue Clamp Meter	19

3000		
3005A	Digital Insulation/Continuity Tester	30
3007A	Digital Insulation/Continuity Tester	30
3021	Digital Insulation/Continuity Tester	31
3022	Digital Insulation/Continuity Tester	31
3023	Digital Insulation/Continuity Tester	31
3131A	Analogue Insulation/Continuity Tester	32
3132A	Analogue Insulation/Continuity Tester	32
3161A	Analogue Insulation/Continuity Tester	33
3165	Analogue Insulation Tester	33
3166	Analogue Insulation Tester	33
3025A	High Voltage Insulation Tester	35
3121B	High Voltage Insulation Tester	34
3122B	High Voltage Insulation Tester	34
3123A	High Voltage Insulation Tester	38

3124	High Voltage Insulation Tester	39
3125A	High Voltage Insulation Tester	35
3127	High Voltage Insulation Tester	36
3128	High Voltage Insulation Tester	37
3431	Analogue Insulation Tester	33

4000		
4102A	Earth Tester (Soft case model)	43
4102A-H	Earth Tester (Hard case model)	43
4105A	Earth Tester (Soft case model)	43
4105A-H	Earth Tester (Hard case model)	43
4105DL-H	Earth Tester (Hard case model)	42
4106	Earth Tester	44
4200	Earth Clamp Tester	45
4202	Earth Clamp Tester	45
4300	Simplified Earth Tester	44
4118A	LOOP/PSC Tester	46
4140	LOOP/PFC/PSC Tester	47

5000		
5010	AC Current Logger	64
5020	AC Current/Voltage Logger	64
5201	Digital Illuminometer	69
5202	Digital Light Meter	69
5406A	RCD Tester	48
5410	RCD Tester	49
5510	Infrared Thermometer	70
5711	Voltage Detector	70

6000		
6010B	Multi Function Tester	52
6011A	Multi Function Tester	53
6016	Multi Function Tester	54
6018	Multi Function Tester	51
6024PV	PV Insulation Earth Tester	56
6201A	Portable Appliance Tester	50
6305	Power Meter	60
6305-01	6305+8125x3+9125	61
6305-03	6305+8130x3+9135	61
6315	Power Meter	62
6315-01	6315+8125x3+9125	63
6315-03	6315+8130x3+9135	63

7000		
7025	Test leads	33,74
7066A	Test leads	10,11,19,20,23,72,74
7073	2WAY Output cord	26,74
7082	Leads for recorder	39,74
7083	Leads for battery charging	39,74
7084	Earth and guard leads	39,74
7095A	Earth resistance test leads	43,51,74
7100A	Precision measurement cord set	43,51,74
7103A	Test leads with remote control switch	31,51,74
7107A	Test leads	19,21,22,74
7115	Extension probe	31,51,74
7116	Extension probe	33,74
7121B	Distribution board test leads	46,48,50,74
7122B	Test leads	30,32,52,53,74
7123	Molded plug test lead [AU]	46,48,50,74
7124	Molded plug test lead [UK]	46,48,74
7125	Molded plug test lead [EU]	46,48,74
7126	Molded plug test lead [SA]	46,48,74
7127A	Simplified measurement probe	43,75
7127B	Simplified measurement probe	42,75
7128A	Test leads	49,75

PRODUCT INDEX

7129A	Test lead with alligator clip	49,50,75	8019	Hook type prod	34-36,38
7131B	Safety crocodile clip [black]	31,51	8022	AC adaptor [110V]	22
7132A(KSLP5)	External earth probe	53,75	8023	AC adaptor [220V]	22
7133B(OMA DIEC)	Distribution board test leads	52,53,75	8029	Extension prod	37
7139A	Test leads with remote control switch	74	8030	Phase indicator	71
7140	Adaptor for extension cord	50	8031	Phase indicator	71
7141B	Voltage test lead set	60,62,75	8031F	Phase indicator	71
7146	Banana ϕ 4 adjuster plug	15,67,68,75	8032	Auxiliary earth spikes [2 spikes/set] x 1set	43,44,51,55,74,77
7148	USB cable	60,64	8035	Non-contact Phase Indicator	71
7149A	Test leads with remote control switch set	33,75	8041	Auxiliary earth spikes [2spikes/1set]	42,78
7150A	Test leads with remote control switch set	31,75	8072	CAT II Standard prod	44,56,57
7153B	Safety test leads	75	8075	Battery charger [120V]	39
7154B	Safety test leads	75	8080	Battery charger [220V]	39
7155B	Safety test leads with fuse	75	8112	AC Clamp Adaptor	27
7156B	Safety test leads with fuse	75	8112BNC	AC Clamp Adaptor	27
7157B	Safety crocodile clips	75	8115	Clamp Sensor	10,15,27
7158B	Safety crocodile clips for fuse	75	8121	Load current Clamp Sensor	15,64,66,68
7159B	Safety test leads with fuse	75	8122	Load current Clamp Sensor	15,64,66,68
7161A	Flat test prod [black]	31,50,51	8123	Load current Clamp Sensor	15,64,66,68
7165A	Line probe	34-36,38,76	8124	Load current Clamp Sensor	60-63,66,67
7168A	Line probe with alligator clip	34-36,38,76	8125	Load current Clamp Sensor	60-63,66,67
7170	Power cord	37,60,62,76	8126	Load current Clamp Sensor	60-63,66,67
7185	Extension cable	64,66-68,76	8127	Load current Clamp Sensor	60-63,66,67
7187A	Main test lead [UK]	47,55,76	8128	Load current Clamp Sensor	60-63,66,67
7188A	Distribution board fused test leads	55,76	8129	Flexible Clamp Sensor	60-64,66,67
7196A	Test leads with remote control switch	55-57,76	8130	Flexible Clamp Sensor	60-63,66,67
7199	Output cable	67,76	8141	Leakage current Clamp Sensor	66,68
7218A	Main test lead [EU]	47,55,76	8142	Leakage current Clamp Sensor	66,68
7219	USB cable	62,76	8143	Leakage current Clamp Sensor	66,68
7220A	Test leads	14,76	8146	Leakage & Load current Clamp Sensor	15,62-64,66,68
7221A	Main test lead [SA]	47,55,76	8147	Leakage & Load current Clamp Sensor	15,62-64,66,68
7222A	Main test lead [AU]	47,55,76	8148	Leakage & Load current Clamp Sensor	15,62-64,66,68
7224A	Earth cord	36-38,76	8161	Clamp Sensor	10,27
7225A	Guard cord	36-38,76	8200-03	Cord reel [3pcs]	43,51,74,77
7226A	Line probe	37,76	8200-04	Cord reel [4pcs]	44
7227A	Line probe with alligator clip	37,76	8201	Output plug	19,22
7228A	Earth resistance test leads	55,77	8212-RS232C	RS232C adaptor with "KEW Report(Software)"	44,52,55
7229A	Earth resistance test leads	44,77	8212-USB	USB adaptor with "KEW Report(Software)"	37,44,52,55-57
7234	Alligator clip	10,11,15,77	8212-USB-W	USB adaptor with "KEW Windows(Software)"	37
7238A	Simplified measurement test leads	44,77	8216	Temperature probe	11,23,78
7243	L-shaped probe	33,56,57,77	8241	USB Communication set	15
7244A	Alligator clip	56,57,77	8247	Thermal paper for printer	15
7245A	Precision measurement cord set	56,57,77	8253	CAT III Standard prod	44
7246	Distribution board test lead	47,77	8255	CAT IV Standard prod	37
7247	Distribution board test lead	47,77	8258	USB communication set	36
7248	Test leads	44,77	8259	Adapter for measurement terminal	42,43
7253	Longer line probe with alligator clip	34-36,38,77	8302	Adaptor for recorder	35,36
7254	Longer line probe with alligator clip	37,77	8304	Resister for operation check	45
7256	Output cord	19,22,24,77	8309	Voltage sensor	64,66
7260	Test lead with remote control switch set	33,77	8312	Power supply adaptor	60,61,63,66
7261	Test lead with Alligator clip	33,77	8320	AC adaptor	24,64,66
7264	Earth cord	34,35,77	8324	Adaptor for recorder	34,38
7265	Guard cord	34,35,77	8326-02	SD card [2GB]	60,62
7266	Earth resistance test leads	42,78	8327EU	Power adaptor 15V/1A	36
7267	Cable reel for Earth resistance tester (Red)	42,78	8405	Temperature probe	15,78
7268	Cable reel for Earth resistance tester (Yellow)	42,78	8406	Temperature probe	15,78
7269	Earth resistance test lead (Red)	78	8407	Temperature probe	15,78
7270	Earth resistance test lead (Yellow)	78	8408	Temperature probe	15,78
7271	Earth resistance test leads (Green)	42,78	8901	Fuse [0.5A/250V]	11,79
7272	Precision measurement Cord set	42,78	8918	Ceramic fuse [0.8A/600V]	11,79
8000			8919	Ceramic fuse [10A/600V]	10,11,79
8016	Hook type prod	31,33,51,56,57	8923	Fuse [500mA/600V]	11,19,30-32,61,66,79
8017	Extension prod	31,33,44,49,51,56,57	8926	Fuse [440mA/1000V]	14,79
8017A	Extension prod long	33	8927	Fuse [10A/1000V]	14,79

PRODUCT INDEX

9000		
9029	Carrying case	71
9057	Carrying case	27
9070	Carrying case	71
9071	Carrying case	22
9074	Cord case	30,32,33
9079	Carrying case	20
9084	Soft case	43
9089	Carrying case	31
9090	Carrying case	20,23,25
9091	Carrying case for cord reels	43,51,74
9092	Cord case	51-53
9094	Carrying case	19,22,23,26,67,68,71
9095	Carrying case	11,67,68
9096	Carrying case	24,71
9097	Carrying case	10,19,25,26
9103	Carrying case	11
9107	Soft case	13
9113	Carrying case	26
9114	Carrying case [Hard]	12
9115	Carrying case [Soft]	12
9118	Carrying case [Soft]	64
9120	Cord case	31
9121	Shoulder strap	30-33,42-44,46,48-51,53,55
9123	Shoulder strap	33
9125	Carrying case	44,60-63
9130	Carrying case	12
9132	Carrying case with magnet	60,61,63,66
9135	Carrying case	61,63,64,66
9137	Carrying case	67
9142	Carrying case	55,77
9147	Cord case	46,48-50
9148	Shoulder strap	52
9154	Carrying case	15
9155	Shoulder strap	47,56
9156	Soft case	47,56,57
9158	Carrying case [Hard]	38
9160	Carrying case	21
9161	Carrying case	44
9164	Carrying case [Hard]	43
9165	Carrying case [Hard]	43
9166	Carrying case [Hard]	45
9167	Carrying case [Hard]	45
9168	Carrying case	11
9171	Carrying case [Hard]	36
9173	Carrying case	33
9174	Carrying case	21
9176	Carrying case [Hard]	39
9180	Carrying case [Hard]	35
9181	Carrying case [Hard]	35
9182	Carrying case [Hard]	34
9183	Carrying case [Hard]	34
9188	Hard case	12
9189	Magnet hanger strap	10
9191	Hard case	42
9192	Carrying case for cord reels	42,78
KAMP10	Test lead with IEC connector	52,53,78
KT170	Voltage Tester	73
KT171	Voltage Tester	73
KT200	Digital Clamp Meter	72
KT203	Digital Clamp Meter	72
Ni-Cd rechargeable battery		39

QUALITY CONTROL CONCEPT

Kyoritsu started early an effort to establish system that ensures traceability to the national standards in order to produce reliable instruments as well as instruments that can assure reliability of other equipment and installations.

When traceability is in place, measurements taken with an instrument any time and anywhere in any situation can be related to the appropriate national measurement standards through a clear and unbroken chain of comparisons.

For example, in terms on measurement defined by JIS (Japanese Industrial Standards), traceability is specified as a condition in which a calibration path is established from instruments produced or in-house standards to higher level standards to the national standards. Kyoritsu currently has a system in place as shown in the figure below.

Our calibrator (standard) is calibrated at Japan Electric Meters Inspection Corporation (JEMIC), Japan Quality Assurance Organization (JQA) and Fluke Japan who perform calibration based on the units established and maintained by National Institute of Advanced Industrial Science and Technology (AIST). The standard is used as the in-house standard to calibrate all the test and measuring equipments which are used in-house.

Voltage : Precision calibrators are used as in-house DC and AC voltage standards.

Current : DC or AC current is converted to a voltage by a standard resistor, and the voltage is calibrated with a precision digital multimeter.

Resistance : Calibration resistors are calibrated with a DC standard current generator and the precision digital multimeter.

Calibration System for Electrical Measuring Instruments

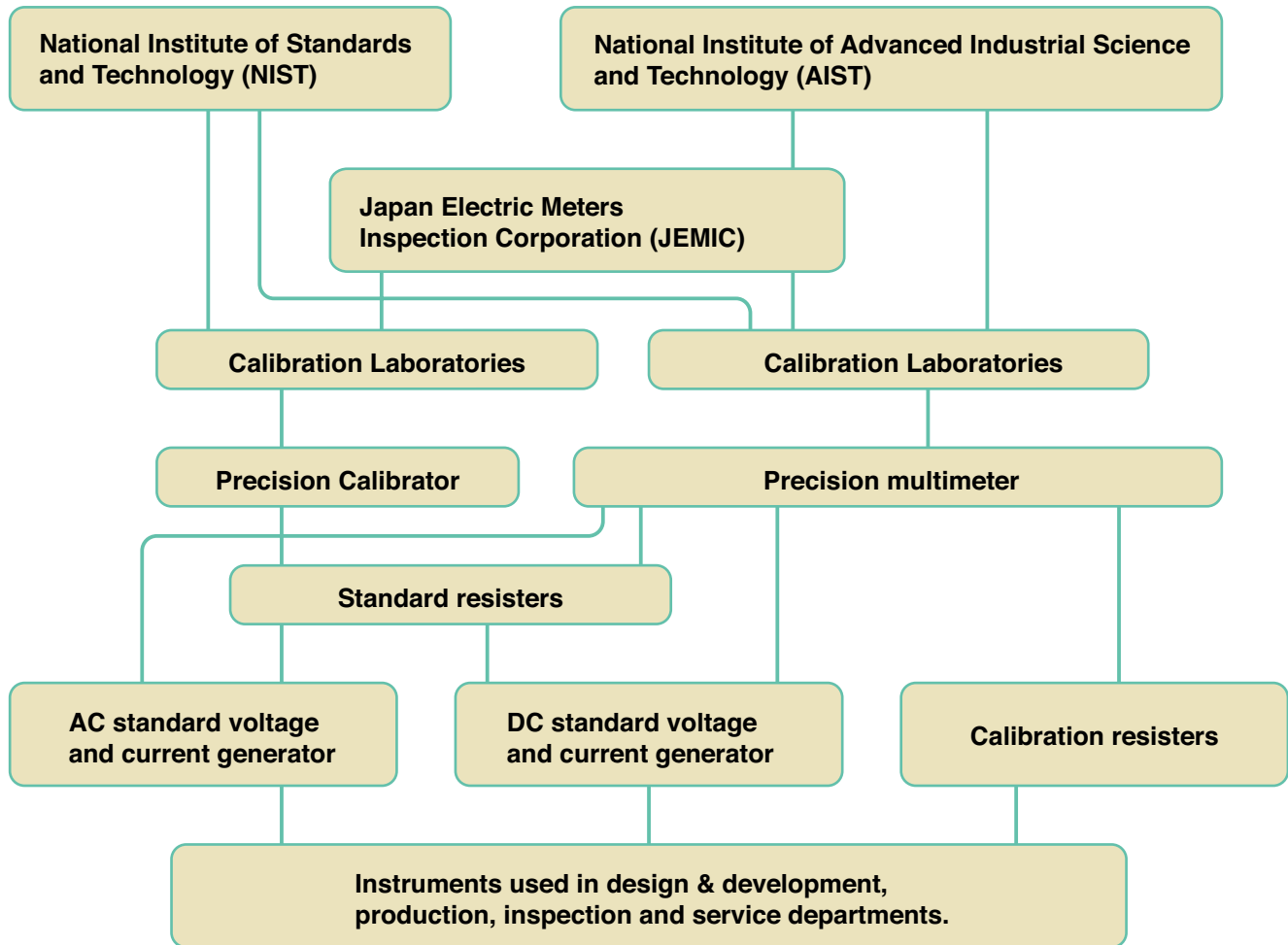

CE Marking: signifies conformance to
EMC directive (2014/30/EU)
LVD directive (2014/35/EU)
RoHS directive (2011/65/EU)

KYORITSU GLOBAL NETWORK



● **KYORITSU ELECTRICAL INSTRUMENTS WORKS, LTD.**

No.5-20, Nakane 2-chome,
Meguro-ku, Tokyo, 152-0031 Japan
Phone: +81-3-3723-0131
FAX: +81-3-3723-0152
URL: <http://www.kew-ltd.co.jp>
E-mail: info-eng@kew-ltd.co.jp
Factory: Ehime

● **KEW EUROPE OFFICE**

Viale Rimembranze 93/18,
20099 Sesto S. Giovanni (MI) Italy
Phone: +39-02-38238685

● **KEW (THAILAND) LIMITED**

Navanakorn Industrial Estate60/48, Moo 19,
Klongluang,Pathumthani, 12120 Thailand
Phone: +66-2-529-0542
FAX: +66-2-529-0541

● **KYORITSU SHANGHAI TRADING COMPANY LIMITED**

Room1303, No.58 Yan'an East Road,
Huangpu District, Shanghai 200002, China
Phone: +86-21-6321-8899
FAX: +86-21-5015-2015
URL: <http://www.kew-ltd.com.cn>
E-mail: info@kew-ltd.com.cn

● **KEWTECH CORPORATION LIMITED**

Midas House, Unit 2b Stones Courtyard,
High Street, Chesham, Buckinghamshire,
HP5 1DE, England
Phone: +44-1494-792212
FAX: +44-1494-791826

● **KYORITSU INSTRUMENTS ASIA PTE. LTD.**

153B Rochor Road, #03-00 Bugis Village
Singapore 188428
Phone: +65-6336-3398
FAX: +65-6366-1696



Safety Warnings :

Please read the "Safety Warnings" in the instruction manual supplied with the instrument thoroughly and completely for correct use. Failure to follow the safety rules can cause fire, trouble, electrical shock, etc. Therefore, make sure to operate the instrument on a correct power supply and voltage rating marked on each instrument.

■ For inquires or orders :